



Alexandria University
Alexandria Engineering Journal
www.elsevier.com/locate/aej
www.sciencedirect.com



REVIEW

Absorption cooling systems – Review of various techniques for energy performance enhancement



Rasoul Nikbakhti^{a,*}, Xiaolin Wang^a, Ahmed Kadhim Hussein^b, Aghil Iranmanesh^c

^a School of Engineering, College of Sciences and Engineering, University of Tasmania, Tasmania, Australia

^b Department of Mechanical Engineering, College of Engineering, University of Babylon, Babylon City, Hilla, Iraq

^c Department of Mechanical Engineering, University of Jiroft, Jiroft, Iran

Received 31 December 2018; revised 23 September 2019; accepted 19 January 2020

Available online 21 February 2020

KEYWORDS

Absorption cooling system;
 Energy performance;
 Low-grade heat sources;
 Different cycles;
 Heat recovery;
 Working fluid pair

Abstract Absorption refrigeration technology was introduced to address some serious issues such as the energy crisis, increased fuel prices, and environmental problems associated with the conventional compression refrigeration systems. It has attracted an increasing deal of interest thanks to such advantages as utilization of low-grade heat sources and environment-friendly working fluid pairs. Nevertheless, this technology suffers from two major obstacles including the usually too large size of the cooling unit and the low coefficient of performance (COP), preventing the absorption systems from being commercially successful. Numerous research works have been done to develop strategies in order to improve the COP of the absorption systems, so as to make the absorption refrigeration technology more competitive with the conventional compression refrigeration systems. In this paper, it is intended to conduct a literature review on various technologies implemented to improve the COP of absorption refrigeration systems. Among effective and promising workarounds for increasing the COP of absorption refrigeration systems, this work refers to cycle design improvement, heat recovery method, development of new working pairs, adding sub-components, and improvement of operating conditions.

© 2020 The Authors. Published by Elsevier B.V. on behalf of Faculty of Engineering, Alexandria University. This is an open access article under the CC BY-NC-ND license (<http://creativecommons.org/licenses/by-nc-nd/4.0/>).

Contents

1. Introduction	708
2. Absorption technology	708
3. Improvement of absorption systems	710
3.1. Development of cycle design	710

* Corresponding author at: School of Engineering and ICT, University of Tasmania Private Bag 65, Hobart Tasmania 7001, Australia.
 E-mail address: Rasoul.nikbakhti@utas.edu.au (R. Nikbakhti).

Peer review under responsibility of Faculty of Engineering, Alexandria University.

3.1.1.	Single-effect and Single-effect double-lift cycles	710
3.1.2.	Double-effect cycle	711
3.1.3.	Multi-effect and multi-stage cycles	712
3.2.	Absorption heat recovery cycles	716
3.2.1.	Basic GAX cycle	717
3.2.2.	Branched GAX cycle	718
3.2.3.	Absorber heat recovery cycle	718
3.2.4.	Other advanced heat recovery cycles	718
4.	Improvement of absorption structures and mechanism	720
4.1.	Operating fluid pairs	720
4.2.	Combined systems (Added components and sub-components)	724
4.2.1.	Refrigerant and solution heat exchangers	725
4.2.2.	Flash tank	726
4.2.3.	Distillation column	726
4.2.4.	Ejector	727
4.2.5.	Compressor	728
5.	Improvement of operating conditions	729
6.	Current and future aspects of developments	733
7.	Conclusion	733
	Declaration of Competing Interest	734
	References	734

1. Introduction

Over the past decades, there has been substantial growth in the demand for cooling, refrigeration, and air conditioning devices to fulfill various engineering and comfort requirements. According to the International Institute of Refrigeration (IIR), conventional vapor compression refrigeration systems (VCRS) consume some one-fifth of all the electricity generated worldwide. The consumption rate is anticipated to rise to half of the rate consumed by domestic buildings and commercial centers over the few coming years. [1]. The dramatic rise in energy consumption for such applications has exerted intense pressure on conventional energy sources so that the end of fossil fuels will come soon unless appropriate actions are taken immediately. Furthermore, the increasing demand for energy has risen the prices, emphasizing the need for increasing the supply of energy by either exploring new sources of energy or saving the existing sources of energy through reducing the energy consumption rate. The exploitation of renewable energies (*e.g.* the waste heat produced through industrial processes and wind and solar energies) to operate refrigeration systems has become an increasingly interesting field of research in recent years thanks to their sustainable yet abundant availability [2–5].

The enormous amount of energy consumed to power the compressors in the conventional VCRSs produces large volumes of greenhouse gases, contributing to many environmental issues. In addition, conventional refrigerants (*e.g.* hydrocarbons (HCs) and hydrochlorofluorocarbons (HCFCs)) for conventional VCRSs are known to contribute to ozone depletion and global warming. The international community has made significant efforts to protect the ozone layer and the ecological environment, including the restriction of the use of chlorofluorocarbons (CFCs) and HCFCs under the two important protocols adopted in 1987 (Montreal) and 1997 (Kyoto). Despite these efforts, the hole in the ozone layer has expanded from about 24,000,000 km² in 1994 to some 28,300,000 km², according to NASA [6]. In October 2000, the European Com-

mission (EC) adopted a resolution to prohibit all HCFCs by 2015 [7,8]. Average global temperature has increased by 0.6 K since the beginning of the present century, based on a report by an institute on climate change, and it is expected to rise by 1.4–4.5 K by 2100 if the current trend continues [9].

Considering the environmental problems caused by conventional VCRSs, an alternative green technology to replace the conventional refrigeration systems is highly demanded. The emergence of novel refrigeration technologies has been realized upon the research on the use of waste heat and renewable energies. These technologies not only attenuate the greenhouse effect but also preserve other sources of energy. Among others, these technologies suggest alternative working fluids that impose neither any damage to the ozone layer nor any contribution to global warming.

2. Absorption technology

Among similar technologies, the absorption refrigeration system offers a highly promising alternative to conventional VCRSs and has hence attracted many researchers during the recent past. The absorption refrigeration system is defined as a thermally driven refrigeration technology for exploiting the heat from low-grade energy sources for cooling purposes.

As shown in Fig. 1, an absorption system consists of four main components, namely the generator, the condenser, the evaporator, and the absorber. Instead of using a compressor, the system uses an absorber to rise and carry the weak coolant through a pump when the heat is supplied to the generator. In the evaporator, the refrigerant is vaporized upon absorbing the heat for the sake of cooling. The vapor is then absorbed by the weak solution that is actively cooled in the absorber. Next, the diluted solution is pumped to the generator where the refrigerant vapor is thermally desorbed from the solution and dispatched to the condenser where it is condensed. Thereafter, the liquid refrigerant phase expands to a lower pressure through an expansion valve and flows back to the evaporator

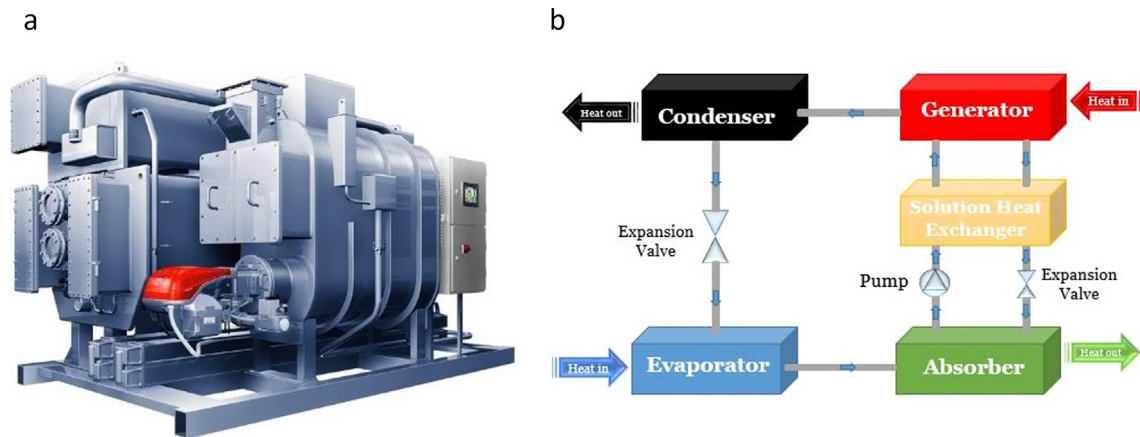

Fig. 1 (a) Absorption refrigeration machine (b) General schematic of absorption system.

to make up the evaporator refrigerant. At the same time, the strong solution is throttled back to the absorber through a heat exchanger to absorb the refrigerant vapor coming from the evaporator; this cycle is repeated during the process.

According to Henning, absorption refrigeration systems are responsible for almost 60% of all installed thermally driven refrigeration systems in Europe [10].

The following list presents several advantages of absorption refrigeration systems:

- i. Absorption refrigeration systems can be thermally driven by low-grade heat sources (*e.g.*, engine exhaust) and renewable sources of energy (*e.g.*, solar energy). This makes the system very effective in the reduction of CO₂ emission and very promising in saving energy;
- ii. Absorption refrigeration systems work based on environment-friendly refrigerants such as water, minimizing their impact on the ozone layer and global warming;
- iii. Absorption refrigeration systems operate quietly as those have almost no high-speed moving parts. This also makes their maintenance cheap and easy;
- iv. Absorption refrigeration systems offer heat recovery from virtually any system;
- v. With an absorption refrigeration system, there is no cycling loss during on-off operation during which the conventional VCRSs are known to produce lots of waste heat; and
- vi. Absorption refrigeration systems are very durable with expected lifetimes of 20–30 years.

Despite their benefits, the absorption refrigeration systems still suffer from a relatively low energy performance in comparison with the conventional VCRSs. Fig. 2 presents the main advantages and disadvantages of the absorption refrigeration technology. In order to overcome the serious challenges and promote the application of the absorption technology, many works with different focuses have been represented to enhance the coefficient of performance (COP) and cooling capacity (CC).

Coefficient of performance which is adopted to evaluate the efficiency of absorption cooling system is defined as follow:

$$COP = \frac{\text{quantity of cooling power produced in the system}}{\text{quantity of heat applied to operate the system}}$$

A number of review papers on the absorption cooling technologies can be found in the literature, with each review paper focusing on one or more specific aspects of the absorption technology, keeping the literature lacking a comprehensive review presenting all developments related to this technology. The present work is an attempt to present such a comprehensive review. We present nearly all effective techniques and strategies applied to improve the COP and CC for absorption cooling systems (Fig. 3). The improvements in absorption technology are herein classified into three main parts, with each part discussed in some sub-sections. In the first part, all advanced absorption cycles proposed for improving the system performance are described in detail. This part is divided into two sub-sections to cover the effective cycles in terms of advanced cycle design and heat recovery cycles. The second part focuses on the improvement of absorption structures

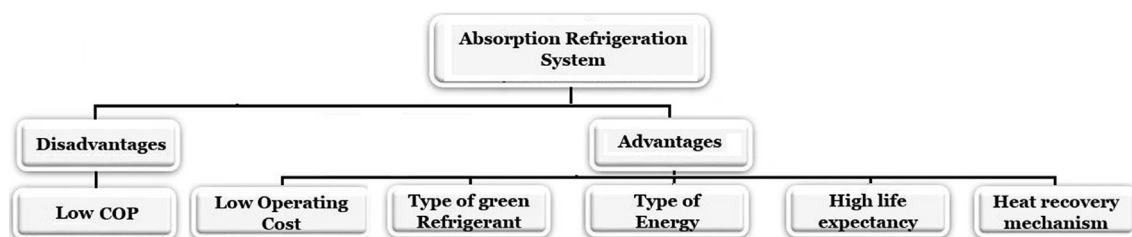

Fig. 2 Main advantages and disadvantages of absorption refrigeration technology.

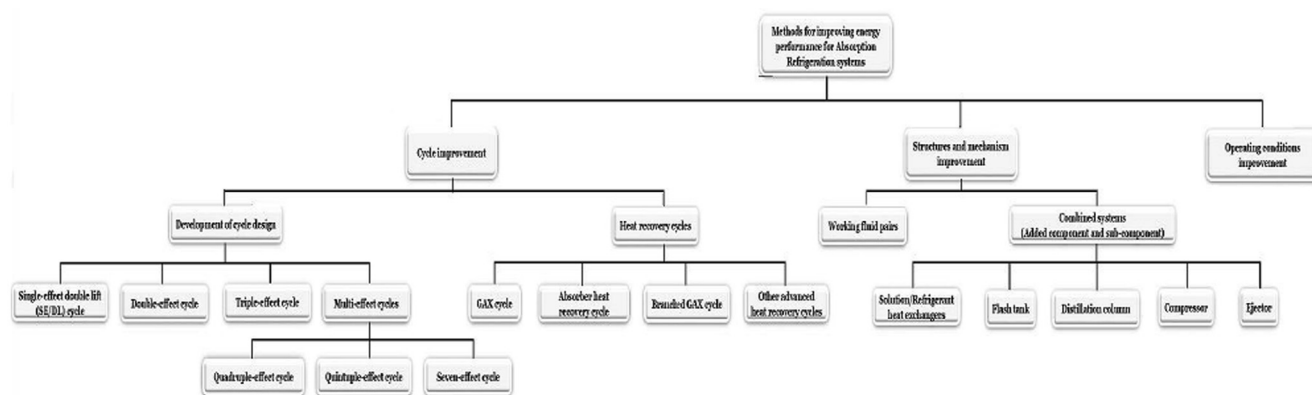

Fig. 3 Main approaches for improving the energy performance for absorption system.

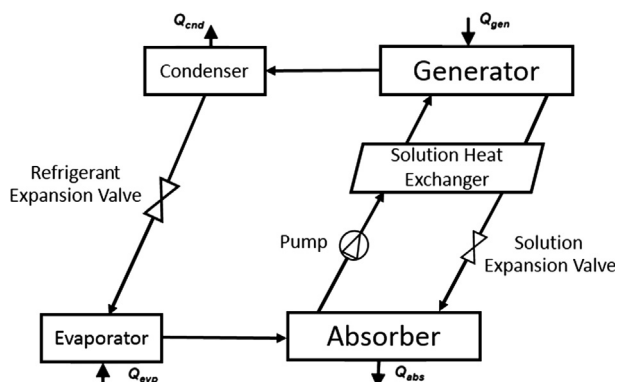

Fig. 4 Schematic of single-effect absorption refrigeration system.

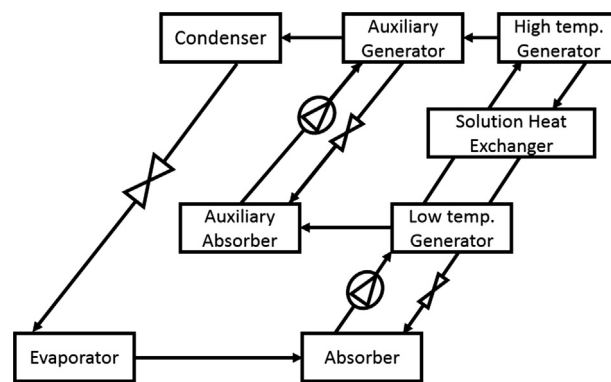

Fig. 5 Schematic of single-effect double-lift absorption refrigeration system.

and mechanism. The effects of different working fluid pairs and addition of sub-components on the system performance are studied in this part. Finally, effects of various design and operating parameters on the efficiency in absorption technology are investigated in the third part (see Fig. 4).

3. Improvement of absorption systems

3.1. Development of cycle design

3.1.1. Single-effect and Single-effect double-lift cycles

The simplest configuration of an absorption refrigeration system is a single-effect cycle. Numerous analytical, numerical and experimental investigations have been performed to analyze the efficiency of single-effect absorption systems with different working fluid pairs under a variety of operating conditions [11–13]. Different effective strategies have been adopted to increase the energy performance of single-effect absorption systems; these include optimizing the operating conditions and selecting novel working fluid pairs with better thermodynamic properties than the conventional working pairs. Nevertheless, COP of the single-effect absorption refrigeration systems is still less than enough.

The energy efficiency of a single-effect absorption cycle drops significantly when less than enough heat energy is available to operate the machine. In order to address this issue,

single-effect double-lift absorption cycle was proposed (Fig. 5) to run the system with lower heat energy than that needed for driving a single-effect absorption system at performance levels comparable to that of the single-effect cycle.

The single-effect double-lift absorption cycle was, indeed, an integration of a basic single-effect system with a double-lift mechanism that could work with low-grade heat sources at down to 55 °C [14,15]. As a result, a single-effect double-lift system can serve as a single-effect system for working with low-grade heat sources (e.g., solar and geothermal energies). As another advantage of a single-effect double-lift system, larger cooling capacities can be obtained from a given heat source using such systems, as compared to a single-effect absorption system. Schweigler et al. [16] disclosed a single-effect double-lift absorption cooling system with an energy performance changing between 0.35 and 0.7. The obtained performance was slightly higher than the basic single-effect absorption cycle. Moreover, the cycle was able to be operated by low-grade thermal energy like the geothermal and solar energy.

A single-effect double-lift absorption cycle driven by solar energy was then analysed by Yattara et al. [17]. Upon incorporating a double-lift mechanism into the single-effect process, smaller heat exchanger area could be used to produce 2.5–18% higher performance. Recently, an air-cooled double-lift cycle using $\text{NH}_3\text{-H}_2\text{O}$ solution was investigated numerically [18] and experimentally [19]. The system achieved a performance improvement of 0.34 with hot water at 85 °C, cooling

air at 35 °C, and evaporation temperature of 10 °C. Yan et al. [20] presented an advanced single-effect double-lift absorption cycle. The proposed system provided a performance level higher than that of a single-effect cycle but still lower than that of a double-lift cycle. It was also observed that the amount of heat consumed to run this cycle was considerably smaller than that was necessary for operating the single-effect cycle. Alejandro et al. [21] investigated a single-stage LiBr absorption chiller driven by low-grade heat source temperatures. The authors established an optimal control technique in their work and managed to improve the system COP considerably. In addition, the energy consumption and the operational cost of the absorption refrigeration system were also reduced. Lopez Zavala et al. [22] developed a novel LiBr/H₂O absorption cooling and desalination system operated by solar thermal energy and using seawater as a cooling medium with three different pressure levels. The proposed cycle designed in such a way that led to an increase in the cooling and desalination performance. The results revealed that the efficiency enhanced by 19.4% in comparison with a conventional single-effect absorption system.

3.1.2. Double-effect cycle

Many efforts have been made to make absorption systems more competitive with conventional VCRSs. Due to the relatively low performance of the single-effect absorption systems, the double-effect systems were proposed for higher performance [23,24]. In such systems, the generator temperature is higher than that required for operating a single-effect system. A comparative investigation between a single-effect system and a double-effect refrigeration system was conducted by Gomri [25]. The results indicated that the performance of the double-effect cycle was double that of the single-effect cycle. Arora and Kaushik [26] developed a computational model to evaluate the efficiency of a single-effect system and a double-effect system in series flow scheme using H₂O-LiBr solution. The effects of operating conditions including the absorption, generation, condensation, and evaporation temperatures were analysed on the systems efficiency. The results showed that the efficiency of the double-effect system improved by relatively 60–70% as compared to the single-effect system. In addition, the highest COP was obtained at minimal generator temperature; this could be achieved through either cutting down the

condenser and absorber temperatures or increasing the efficiency of the evaporator and solution heat exchanger. Dominguez-Inzunza and his colleagues performed a performance comparison of various layouts of absorption cooling systems employing NH₃-LiNO₃ [27] and H₂O-LiBr [28] solutions. The results further showed that the half-effect cycle could operate at the lowest generator temperature, leading to the lowest evaporation temperature. Furthermore, the double effect cycle was the most effective configuration based on the energy efficiency. Ventas et al. [29] analysed a two-stage NH₃-Li₃N double-effect absorption cycle. The results revealed higher performance of the cycle compared to a typical parallel flow double-effect cycle with the same working fluid pair under the same operating conditions. The maximum COP was achieved 1.25 when a heat source of 100 °C temperature was applied in the generator. In another investigation, Lubis et al. [30] combined the single-effect and the double-effect configurations in one united single-double-effect absorption chiller to compensate the unpredictable availability of solar radiation and cooling load fluctuations. It was found that the performance of the double-effect configuration enhanced significantly by designing the integrated single-double-effect system.

Other than the low energy performance, crystallization and corrosion are the other critical problems encountered in the designing and analysis of a double-effect absorption refrigeration system. Two significant factors such as the heat transfer area and crystallization affecting the design process of a double-effect absorption chiller were examined by Xu and his colleagues [31,32]. The results indicated, with decreasing the solution circulation ratio and/or increasing the heat-recovery ratio, the overall performance and crystallization of the system improve while the total heat-transfer area decreases. Garousi Farshi et al. [33] performed a numerical investigation to examine the influences of working parameters on crystallization problem in three different configurations of double effect H₂O-LiBr absorption refrigeration systems. It was concluded that the parallel and the reverse parallel figures could operate with a wider range of working conditions without crystallization risks compared to the series flow scheme. Han et al. [34] performed a theoretical investigation of dual-heat mode work of double-effect absorption refrigeration system employing LiBr-H₂O solution in parallel flow configuration. They analysed various operating conditions to prevent the crystallization

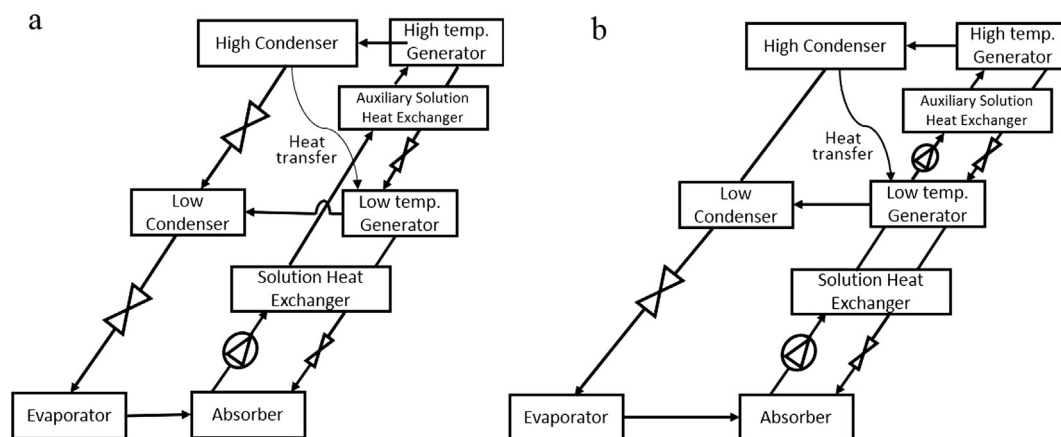

Fig. 6 Schematic of double-effect absorption refrigeration system in (a) series flow scheme and (b) parallel flow scheme.

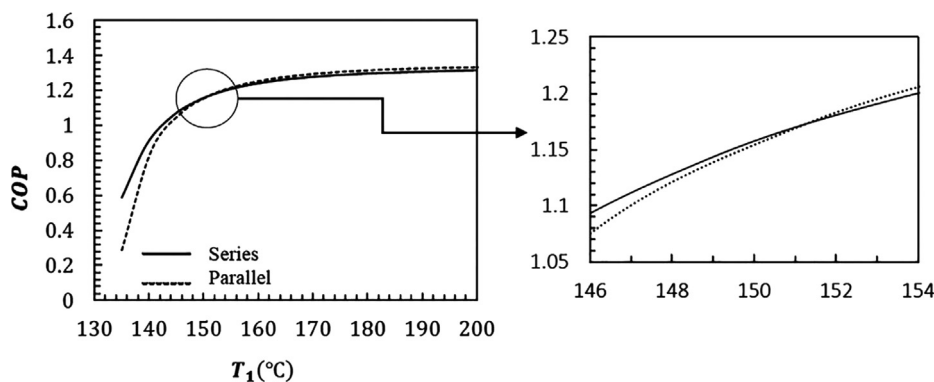

Fig. 7 COP changes for parallel and series cycles versus heat source temperature (Reprinted from Chahartaghi et al. [41], with permission from publisher).

in the system. More recently, Li and Liu [35] carried out a simulation study to analyse the right heat load ratio for the generator in the double-effect absorption refrigeration system with a solution of LiBr-H₂O as an important factor that affected considerably the improvement of the system performance and the reduction of crystallization risk.

For double-effect absorption refrigeration cycles, two main circulation methods for strong and weak solutions can be defined as: the series flow mode and the parallel flow mode demonstrated in Fig. 6. Grossman et al. [36] drew a comparative investigation between different kinds of flow scheme, parallel and series, in a double-effect absorption cycle applying a mixture of LiBr-H₂O to examine the influence of the two schemes of flow on system performance. The results revealed that the system showed greater performance in parallel flow mode as compared to the two types of series flow modes. Moreover, the operating conditions occurred far removed from the crystallization line of LiBr-H₂O solution in the parallel type of flow (see Fig. 7).

A novel high-efficiency water/lithium bromide double effect absorption system exploiting some heat sources including hot water and high temperature steam for tri-generation application was developed by Yang et al. [37]. Five different flow patterns including series, reverse, parallel, revised series and revised reverse were simulated. The efficiencies of the systems were compared based on the order of the generators and the number and place of the additional heat exchangers. Generally, the results indicated that the COPs of revised serial and revised reverse configurations were higher than those of serial and reverse cycles. Furthermore, it was found that the parallel cycle was still superior to other systems from a COP point of view. In addition, the authors reported that the heat source ratio played a significant role in the selection of the best cycle in terms of the efficiency. In this aspect, the revised reverse was the most suitable cycle when the heat source ratio was < 0.7 while the highest COP was obtained for the parallel cycle when heat source ratio was more than 0.7. Garousi Farshi et al. [38] carried out a comparative investigation to analyse the efficiency of double-effect absorption refrigeration system employing a solution of lithium bromide and water. Three configurations including parallel, reverse parallel and series were examined. It was found that the system in the parallel flow layout had the highest performance among the other flow types. Arun [39,40] conducted an investigation to examine the impact

of various parameters like component temperatures and circulation ratio on the performance of a double-effect absorption cooling system in two flow types, named series and parallel flow. The system demonstrated a greater performance for the parallel flow cycle as compared to the series flow. Chahartaghi et al. [41] proposed a novel double-effect absorption chiller with an additional heat recovery heat exchanger using LiBr-H₂O working pair. Two flow arrangements including the series along with the parallel flow schemes were studied. The results revealed that the series configuration provided the greater COP rather than the parallel cycle at inlet vapor temperature to the high temperature generator below 150 °C. In contrast, the parallel scheme was accounted for producing higher performance than the series scheme for heat source temperature higher than 150 °C. In another study, Konwar et al. [42] investigated a double-effect absorption system employing two different working fluids including H₂O-LiBr and H₂O-LiCl with two flow arrangements of series and parallel. They used genetic algorithm to find the optimal combinations of high-pressure generator (HPG) and low-pressure generator (LPG) temperatures for the series scheme along with the optimal distribution ratio (DR) for the parallel mode. The results indicated that the optimal combinations of HPG and LPG for the H₂O-LiCl was lower than that for the H₂O-LiBr. However, the optimal DR was found greater for water-LiCl than that for water-LiBr. In addition, the mixture of H₂O-LiBr showed higher optimum COPs for both flow configurations comparing to the H₂O-LiCl.

3.1.3. Multi-effect and multi-stage cycles

Multi-effect absorption refrigeration cycles, especially the triple-effect absorption cycle, were developed to recover more energy and hence enhance the system efficiency, although those needed higher heat source temperature compared to a double-effect absorption system. A schematic of a triple-effect absorption cycle has been illustrated in Fig. 8 (see Fig. 9).

In comparison to the double effect cycle, there are an additional high-temperature generator as well as a condenser in the triple effect cycle so that the cycle consists of three generators and three condensers. Therefore, this cycle design provides a better energy recovery leading to an improvement in the system efficiency. DeVault and Marsala [43] executed an investigation of a triple-effect ammonia-water absorption

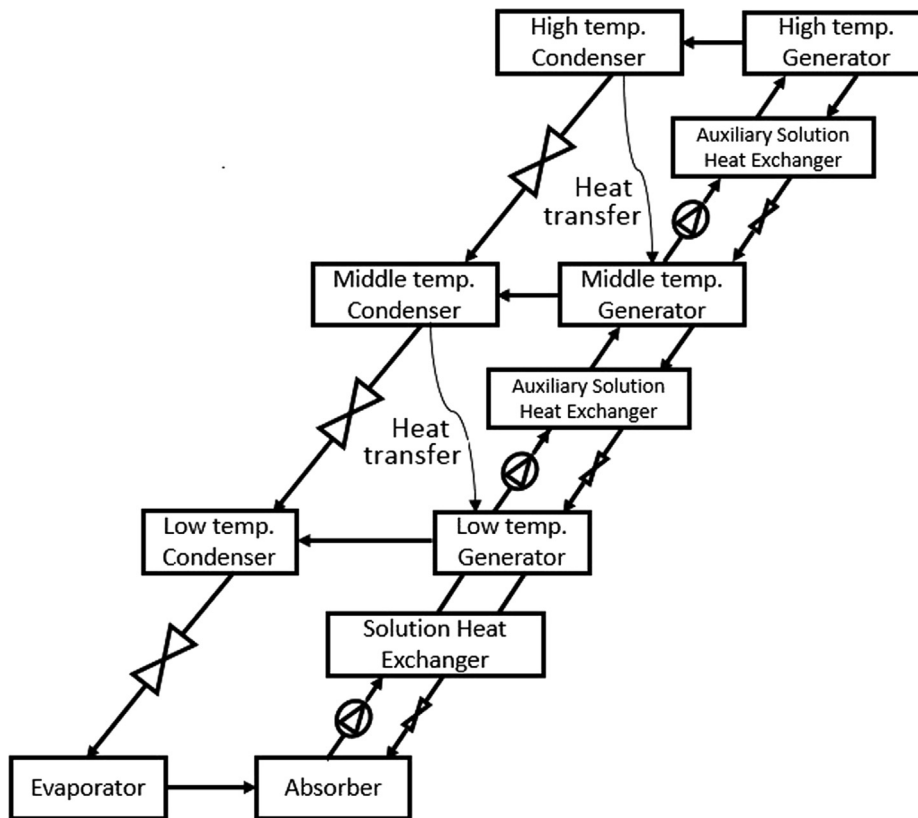

Fig. 8 Schematic of triple-effect absorption refrigeration system.

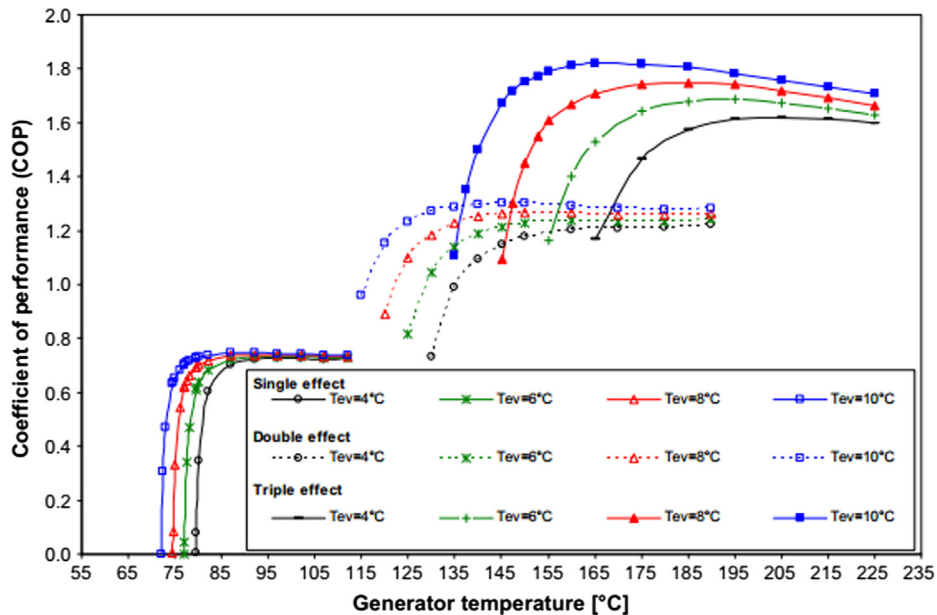

Fig. 9 Variation of COP for single effect, double effect and triple effect cooling absorption systems (Reprinted from Gomri [50], with permission from publisher).

refrigeration system and they found that the efficiency of the system increased by 1.41, 18% greater than that of double effect cycle. In another investigation, Erickson and Tang [44] studied the triple effect absorption cycle and it was observed that the performance of the triple effect cycle enhanced by half

as compared to the double effect cycle. However, the triple-effect cycle needs to be driven by higher heat source temperature.

The initial simplest LiBr-H₂O triple-effect cycle comprising three generators and three condensers studied by Oouchi et al.

[45]. Double condenser coupled was another sort of triple effect cycle which had an additional heat exchanger as compared to the first one [46]. This layout enhanced the system efficiency compared to 3-condenser 3-desorber system. In their system, pre-cooled condensate caused producing further cooling effect and supplying more heat to the lowest desorber led to a higher production of refrigerant vapour in the system. A triple-effect absorption chiller comprising a double-condenser coupled cycle with a COP of 1.4 was developed by Devault and Biermann [47]. Grossman et al. [48] executed a numerical work to analyse the performance of a triple-effect absorption system with LiBr-water solution for different configurations including serial and parallel configurations as well as these flow types with condensed heat recovery. The results revealed that the COP increased from 1.35 to 1.62 for the parallel scheme and it experienced an increase from 1.27 to 1.48 for the series scheme when the heat recovery method was adopted in the system. Kaita [49] examined the effect of different flow configurations including parallel flow, series flow, and reserve flow on the efficiency of a triple stage Li-Br-H₂O absorption refrigeration system. He concluded that the triple effect in parallel type had the highest COP. However, it should be noted that the use of LiBr-H₂O in the triple-effect absorption cooling system might cause corrosion issues when higher heat temperature is applied in the generator. Many researchers performed comparative investigations between the triple-effect absorption cycles and other kinds of absorption cycles. Gomri [50] executed a simulation investigation of single-effect, double-effect and triple effect absorption refrigeration cycles. He found that the effectiveness of a double-effect cycle was roughly two times as large as that of a single-effect system, while a triple-effect cycle offered less than twice performance as that of a comparable single-effect system.

Maryami and Dehghan [51] conducted a comparative investigation between five different types of H₂O-LiBr absorp-

tion refrigeration systems including half, single, double, and triple-effect to examine the impact of various working conditions on the systems performance. The results demonstrated that COP experienced an increase from the half effect to the triple-effect absorption refrigeration systems. Furthermore, increment in the generator temperature resulted in rising the COP of all cycles.

Recently, Alvarez et al. [52] simulated a novel triple-effect absorption refrigeration system named “Alkitrate topping cycle” using aqueous solution of (Li, K, Na) with NO₃. It was revealed from the results that the performance of Alkitrate triple-effect cycle was slightly higher than that of the conventional triple-effect cycle with H₂O-LiBr solution when the generators temperatures exceeded 180 °C. In addition, the proposed cycle did not suffer from some serious problems such as high corrosiveness that occurred at high temperatures associated with the conventional triple-effect cycles using LiBr-H₂O working pair. Li et al. [53] presented a triple-effect absorption cooling system employing three kinds of reactive salts and ammonia solutions as working pairs with internal heat recover to enhance the energy efficiency. The results disclosed that it was possible for the proposed cycle to generate three cooling-effects per cycle with the same cost of a high-grade heat source temperature. Consequently, higher cooling capacity obtained in contrast to the conventional sorption refrigeration cycle. Wang et al. [54] designed a novel system where a heat recovery generator integrated with a triple-effect LiBr-H₂O absorption to enhance the system energy effectiveness. The results revealed that the cycle COP enhanced from 1.78 to 1.83 when the released exhaust temperature experienced a decline from 246.9 °C to 126.4 °C. Lizarte and Marcos [55] carried out a COP optimisation of a triple-effect absorption chiller in parallel configuration using H₂O-LiBr when the heat source temperature was changeable. The results obtained from this research was practical for optimising a

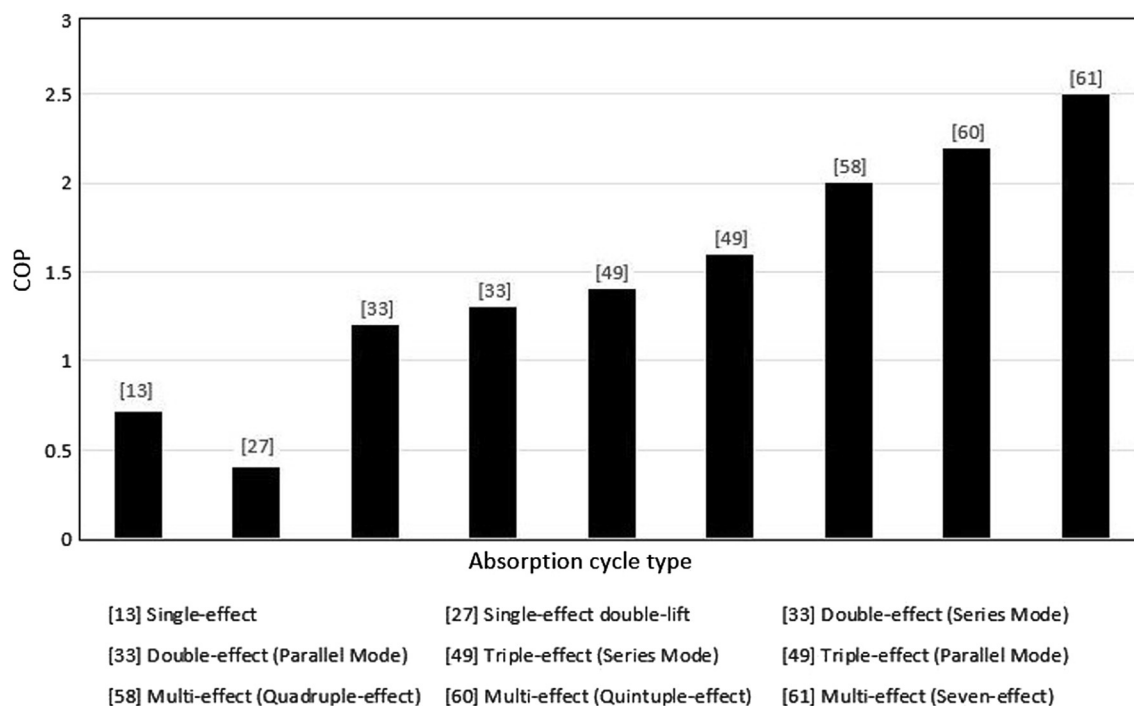

Fig. 10 COP comparison for different cycle design configurations.

Table 1 Summary of some investigations on different types of absorption cycles.

Cycle type	Working fluid	Operating temps. (°C)	COP	Remarks	Ref.
Single effect	H ₂ O-LiBr + LiI + Li-NO ₃ + LiCl	26 < T _a < 60 70 < T _g < 120 26 < T _c < 60 2 < T _e < 5	0.6–0.96	Recommend working situations suitable for air cooled applications without crystallization problem	[11]
Single effect	H ₂ O-LiBr	30 < T _a < 45 80 < T _g < 105 30 < T _c < 45 4 < T _e < 10	0.57–0.82	SHE had more influence on COP than RHE	[12]
Single effect	H ₂ O-LiBr	17 < T _a < 48 58.5 < T _g < 110 17 < T _c < 48 0 < T _e < 30	0.15–0.75	All assumptions and working parameters were declared and justified	[13]
Single effect	LiCl-H ₂ O + LiBr-H ₂ O	31 < T _a < 37 55 < T _g < 90 31 < T _c < 37 1 < T _e < 11	0.12–0.38	The COP was greater in the proposed system compared to the conventional LiBr-H ₂ O system. The series mode was preferable since the system could be operated by low-grade heat source.	[112]
Single effect double lift	TFE-TEGDME + MeOH-TEGDME + NH ₃ - H ₂ O	35 < T _a < 45 65 < T _g < 105 T _c = 35 -5 < T _e < -10	0.2–0.45	The system can be worked by low-grade thermal energy. The COP was larger for both TFE-TEGDME and MeOH-TEGDME than for the ammonia-water	[14]
Single effect	H ₂ O-LiBr	25 < T _a < 50	0.65–0.92	The greatest COP was obtained for the double effect and the half effect required the lowest hot temperatures in generator (between 60 °C and 80 °C)	[28]
Half effect	H ₂ O-LiBr	55 < T _g < 165	0.32–0.45		
Double effect (Series mode)	H ₂ O-LiBr	25 < T _c < 50 2 < T _e < 19	1.1–1.75		
Single effect	LiBr-H ₂ O	25 < T _a < 45	0.65–0.75	The COP of the double effect raised by 60–70% compared to the single effect	[26]
Double effect	LiBr-H ₂ O	120 < T _g < 150 28 < T _c < 36 5 < T _e < 10	1.15–1.3		
Single-double-effect	LiBr-H ₂ O	27 < T _a < 32 70 < T _g < 95 27 < T _c < 32 7 < T _e < 15	1.8–2.1	The COP of the double-effect improved significantly by integrating single-double-effect cycle	[30]
Double effect (Series mode)	H ₂ O-LiBr	30 < T _a < 45	1.17–1.42	The cop for the parallel mode was larger than that for the series mode	[39]
Double effect (Parallel mode)	H ₂ O-LiBr	30 < T _c < 45 2 < T _e < 11	1.32–1.5		
Double effect	H ₂ O-LiBr	33 < T _a < 42 107 < T _g < 207 32 < T _c < 42 4 < T _e < 10	0.9–1.3	Useful information was provided for the selection, design, and control of the double effect system in different modes	[38]
Double effect (series mode)	LiBr-H ₂ O	25 < T _a < 40 85 < T _g < 170 30 < T _c < 45 2.5 < T _e < 10	0.9–1.4	Design working situations were recommended for obtaining the maximum performance	[40]
Double effect	LiBr-H ₂ O	20 < T _a < 35	0.3–1.2	The series mode provided the higher COP when Thw < 150°C but the	[41]

(continued on next page)

Table 1 (continued)

Cycle type	Working fluid	Operating temps. (°C)	COP	Remarks	Ref.
Single effect		$130 < T_g < 200$	0.6–1.19	greater COP was obtained in the parallel mode for $T_{hw} > 150^\circ\text{C}$.	
Double effect		$20 < T_c < 35$			
Triple effect	$\text{H}_2\text{O-LiBr}$	$2.5 < T_e < 10$ $33 < T_a < 39$ $60 < T_g < 225$ $33 < T_c < 39$ $10 < T_e < 15$	0.73–0.79 1.22–1.42 1.62–1.90	For every evaporator and condenser temperatures, there was an optimum generator temperature, in which the system COP reached the maximum value.	[50]
Triple effect “Alkirate topping cycle”	Lithium + Potassium + sodium	$T_{\text{cooling}} = 30$ $T_{\text{hot}} = 250$	1.73	The proposed cycle was able to work efficiently at high temperature heat sources	[52]
Triple effect parallel flow	$\text{H}_2\text{O-LiBr}$	$142 < T_g < 227$ $T_c = 30, 35, 40$ $T_e = 5, 8, 10$	1.05–2.13	The higher T_e and the lower T_c are, the more effective the system will be	[56]

triple-effect absorption chiller thermally operated by solar energy.

Satager et al. [56,57] examined a triple effect cycle that comprised of a single absorption cycle and a double effect cycle. Mixtures of $\text{NH}_3\text{-NiCl}_2$ and $\text{H}_2\text{O-LiBr}$ were adopted in the single absorption cycle at high level of pressure and in the double effect cycle at low level of that, respectively. The results indicated that the system COP was obtained 3.0 which was a very high performance for a triple effect absorption cycle. The quadruple-effect cycle was then proposed in order to provide higher performance than the triple effect cycle although higher driving temperature was also needed. Various arrangements of multi-effect absorption cycles such as the triple-effect and the quadruple-effect were examined by DeVault et al. [43]. Grossman et al. [58] performed a simulation work to analyse the performance of quadruple effect cycle. The results demonstrated that the system COP varied between 2.0 and 2.2 when a high heat source temperature at around 315°C was exploited. Ratlamwala et al. [59] proposed a novel integrated geothermal quadruple-effect absorption system for co-generation of cooling, power and liquefied hydrogen. The results indicated that the system efficiency decreased as the temperature of heat source increased. Moreover, a rise in the mass flow rate of working fluid caused a decrease in the COP, amounts of hydrogen gas pre-cooled and liquefied. A quintuple effect cycle consisted of two sub-cycles [60] was then disclosed to provide greater performance rather than other studied systems. However, like other multi-effect cycles, a high driving temperature was needed for operating the system. DeVault and Biermann [61] disclosed the seven-effect absorption cycle consisted of three sub-cycles; the low-temperature sub-cycle with $\text{H}_2\text{O-LiBr}$ solution and the high-temperature and intermediate-temperature sub-cycles using $\text{H}_2\text{O-NaOH}$ mixture. The seven-effect system was the highest number effect among different types of absorption cycles with a high COP ranged from 2.19 to 3.12.

Fig. 10 compares the COP between different absorption cycle designs to highlight the advantages and disadvantages of various configurations. According to this figure, the COP improves considerably with increasing the number of generators, with the highest COP achieved with the seven-effect cycle. However, multi-effect cycles require very high heat source temperatures (above 200°C) to operate. In contrast, a single-effect double-lift cycle is designed to operate at low-grade heat source temperatures ($60\text{--}80^\circ\text{C}$) but produces the lowest COP at the same time. Among all of the studied arrangements, the single-effect cycle is the simplest and the least expensive system as it requires the minimum number of components to operate. In addition, the system can operate even at moderate generator temperatures ($80\text{--}100^\circ\text{C}$). In the double-effect and triple-effect cycles, higher COPs can be achieved in parallel mode rather than the series mode. Table 1 also provides a summary of some studies performed on various configurations of absorption cycles designed to develop the system performance (see Fig 11).

3.2. Absorption heat recovery cycles

Absorption heat recovery provides a promising and effective approach to improving energy performance in the basic absorption cycles. The recovered heat can then be used to heat

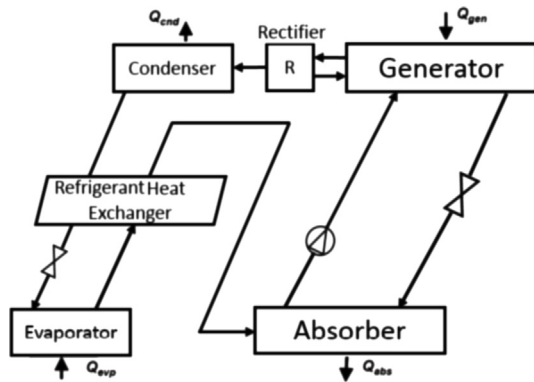

Fig. 11 A schematic diagram of simple GAX cycle.

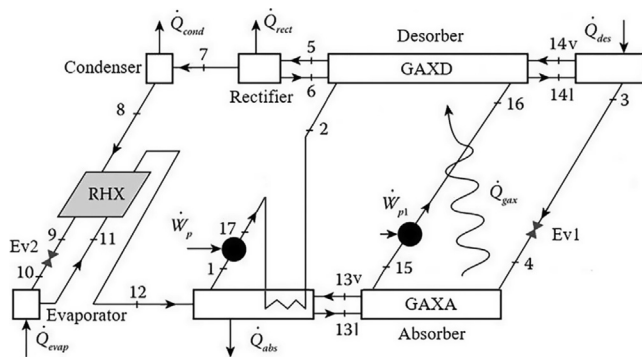

Fig. 12 Schematic diagram of branched GAX cycle (Reprinted from Herold et al. [75], with permission from publisher).

the weak solution leaving the absorber. This, in turn, lowers the needed thermal load of the generator, enhancing the system performance (see Fig 12).

3.2.1. Basic GAX cycle

Although a generator absorber heat exchanger (GAX) cycle represents a single-stage cycle, it provides for higher performances than a standard single-effect cycle (see Fig 13).

Hanna et al. [62] conducted a study to provide a description of operating of a GAX cycle by a pinch-point analysis which is a unique technique whereby the internal heat recovery is a significant feature of cycle design. The GAX has been analyzed by many researchers owing to its merit of providing a higher performance compared to the basic absorption mechanism under the same operating conditions. Priedeman and Christensen [63] conducted a simulation to examine and design a basic GAX absorption cycle using $\text{NH}_3\text{-H}_2\text{O}$ working fluid pair. Zhang et al. [64] investigated a single-effect cycle and a GAX cycle applying $\text{NH}_3\text{-H}_2\text{O}$ solution. The results indicated that the effectiveness of the GAX cycle improved by 32%. Priedeman et al. [65] executed an experimental investigation to analyse the impact of a GAX on the efficiency of an absorption cooling machine with 17.6 kW cooling capacity. The system performance obtained 0.68 under working conditions in which the evaporator, generator, condenser and temperatures were chosen 11.5 °C, 196 °C and 47.2 °C, respectively. Sub-ambient absorber GAX cycle was disclosed by Anand [66] to enhance the system efficiency through increasing the overlap

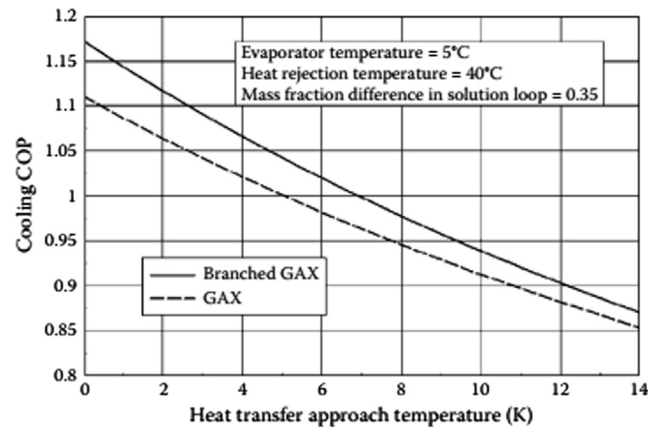

Fig. 13 Variation of COP for GAX cycle and branched GAX cycle (Reprinted from Herold et al. [76], with permission from publisher).

temperature between absorber and generator. Vela 'zquez and Best [67] carried out a thermodynamic examination of an air-cooled GAX cycle operated by hybrid natural gas and solar energy. It was observed that the COP for cooling application was 1.96 when the recovery of heat was 16.9 Kw. Park et al. [68] developed a novel multi-modes ammonia GAX absorption cycle with simultaneous supply of hot and cooling water. The influence of some major parameters including the outlet hot water and the solution heat exchanger on the system performance was investigated for three different modes where the first case illustrated the best energy performance in the system. Saravanan et al. [69] conducted a performance study of a GAX absorption refrigeration cycle where the cooling capacity was chosen to be 40 TR. It was observed that the GAX system experienced a noticeable rise of 30% in the efficiency in comparison to the single effect absorption system. Kang et al. [70] executed an investigation of a GAX hybrid cycle in which, a compressor located between the desorber and the condenser. In contrast to the standard absorption cycle, there was a significant reduction of 30 °C in desorption temperature as well as no change in the condensation pressure. Ramesh kumar and Udayakumar [71] performed a simulation investigation of pressure ratio on low-pressure section of the generator-absorber-exchange absorption compression cycle with $\text{NH}_3\text{-H}_2\text{O}$ solution. In comparison with the conventional GAX cycle, the results revealed that there was a moderate enhancement of 26% in the COP of the proposed system under identical operating conditions. Mehr et al. [72] carried out a performance comparison between a conventional GAX absorption cycle and a hybrid GAX absorption cycle in which a compressor was applied to increase the pressure of absorber. They found that the hybrid GAX cycle enjoyed from a higher performance though its product cost was more expensive than the basic GAX cycle. Dixit et al. [73] performed a comprehensive analysis to study the COP of the aqua-ammonia GAX and hybrid GAX absorption refrigeration cycles under different working conditions. Observations indicated the maximum performance of 0.7–1.1 and 1–1.88 for the GAX and hybrid GAX cycles, respectively, at generator temperatures ranging from 160 °C to 175 °C. In recent years, Du and Wang [74] studied a single stage $\text{NH}_3\text{-H}_2\text{O}$ absorption system for different cooling applications. The authors combined the split cycle and

GAX heat recovery cycle in one united system and managed to improve the energy performance of the system. In comparison with a conventional single stage absorption system, the thermal efficiency of the integrated system enhanced by 25%, 34%, and 20% for three different applications including the freezing, air-conditioning, and space heating, respectively.

3.2.2. Branched GAX cycle

A novel GAX cycle known as “branched GAX cycle” was designed to further improve the performance of the basic GAX cycle, in which the concentrated solution flowing from the absorber toward the generator went through two branches. When the flow rate of solution in the high-temperature branch generator increased, the quantity of the heat applied to the low-temperature branch of the generator was improved. That is the generator could operate by lower heat energy provided an external heat source is available, *i.e.* enhancing the system performance. Therefore, the branched GAX can provide greater performance in comparison with the standard GAX cycle. Moreover, lower heat source temperature was required to drive a branched GAX cycle, as compared to a standard GAX cycle. Herold [75] disclosed a branched GAX cycle and he observed that the cycle performance experienced an improvement of approximately one-fifth compared to the simple GAX cycle. After some years, Herold et al. [76] conducted a simulation to study the branched GAX cycle and compared the system efficiency of the system with the standard GAX cycle at the same working parameters. The results revealed that the system COP improved by 5.7%, rising from 1.11 for the standard GAX cycle to 1.174 obtained in the branched GAX cycle.

An absorption prototype based on the branched GAX scheme was then designed by Erickson et al. [77]. The results indicated that the COP of the machine improved from 0.87 to 0.95 when there was an increase in the ambient temperature from 30.6 to 35 °C. Staicovici [78] showed that a three-stage branched GAX cycle provided 1.25–1.9 times higher COP values in comparison with a three-stage standard GAX cycle. A branched GAX cycle with a ternary mixture of $\text{NH}_3\text{-H}_2\text{O-LiBr}$ was numerically analysed by Zaltash and Grossman [79]. The system performance was compared with a basic GAX cycle using the same working pair. The authors found that the branched GAX cycle efficiency improved considerably as compared to the standard GAX cycle when a high-grade heat source temperature, around 200 °C, was available.

Engler et al. [80] conducted a comprehensive study to compare the energy performance of some advanced configurations. The results disclosed that the highest COP, around 1.08, was obtained for the branched GAX configuration. In recent years, Kholghi and Mahmoudi [81] carried out a study to analyse the branched GAX cooling cycle based on the first and second law of thermodynamics. The authors compared the performances of the branched GAX system and the standard GAX cycle. They found that the branched GAX cycle provided a greater performance from the energy and exergy points of view. Their results indicated that the COP and exergy efficiency of the branched GAX system increased by 14.6% as compared to the basic GAX cycle for the condenser temperature of 30 °C.

3.2.3. Absorber heat recovery cycle

The absorber heat recovery provides another efficient approach to improving the system performance. While flowing

from the absorber toward the generator, the concentrated solution can be preheated in a solution heat exchanger before reaching the generator by the heat absorbed from the diluted refrigerant solution flowing back from the generator toward the absorber. This increases the temperature of the condensed refrigerant solution, lowering the heat applied to the generator and hence increasing the COP. Kandlikar [82] and Kaushik and Kumar [83] conducted theoretical investigations on cycles utilizing the absorber heat recovery scheme and it was found that the performance improved by 10% in the cycles as compared to the conventional absorption cycles. Siddiqui [84] carried out an economic investigation of three different absorption systems with the absorber heat recovery. Three different solution of ammonia with water, sodium thiocyanate (NaSCN) and lithium nitrate (LiNO_3) were chosen. The results revealed that the system performance improved by 20–30% with the use of the water/ammonia solution in the system. In addition, the COP experienced an increase of 33–36% by employing the sodium thiocyanate/ammonia and lithium nitrate/ammonia solutions. On the other hand, the cost of energy decreased to one-third and to one-fourth by applying the mixtures of ammonia with H_2O , NaSCN , and LiNO_3 , respectively. An absorber heat recovery GAX cycle employing $\text{H}_2\text{O-LiBr}$ solution was investigated by Kaushik and Kumar [85]. The authors revealed that the system operated with a higher performance in comparison with the standard absorption cooling system for higher heat source temperatures. However, the cycle was just able to operate in a certain range of operating parameters owing to the crystallization issue related to the selected working pair.

3.2.4. Other advanced heat recovery cycles

In addition to the three main heat recovery methods explained above, other advanced cycles have also been proposed to increase the COP of the single-effect absorption system through improving the heat recovery through the cycle. Regeneration absorption (RA) cycle proposed by Dao [86] was an advanced cycle in which a rise in temperature overlap between the desorber and the absorber caused a further improvement in the cycle performance. The results illustrated that the efficiency of the regeneration absorption cycle raised by relatively 30% as compared to the basic GAX cycle. Other absorption heat recovery cycles such as the double-effect cycle operating with the intermediate pressure [87], and the triple effect cycle along with low-pressure using a resorption process [88] were also disclosed to improve the flexibility of the cycle and the internal heat recovery. Erikson [89] disclosed a number of layouts of vapour exchange duplex GAX cycle aimed at improving the system performance by extending the GAX overlap. Erickson and Tang [90] computationally modelled a double-lift GAX cycles in which the interior heat incorporated between an absorber with a middle pressure and a generator with high pressure. In comparison to the standard double-lift cycle, the results revealed that the COP of the double-lift GAX cycle improved by 20%. More recently, Toppi et al. [91] simulated numerically two types of the semi-GAX cycles, including semi-GAX1 and semi-GAX2. The first type was proposed for establishing the GAX effect at high to moderate pressures, whereas the second one was focused on the moderate to low pressures. The authors studied the influence of the split ratio on the cycle efficiency under different air temperatures. They

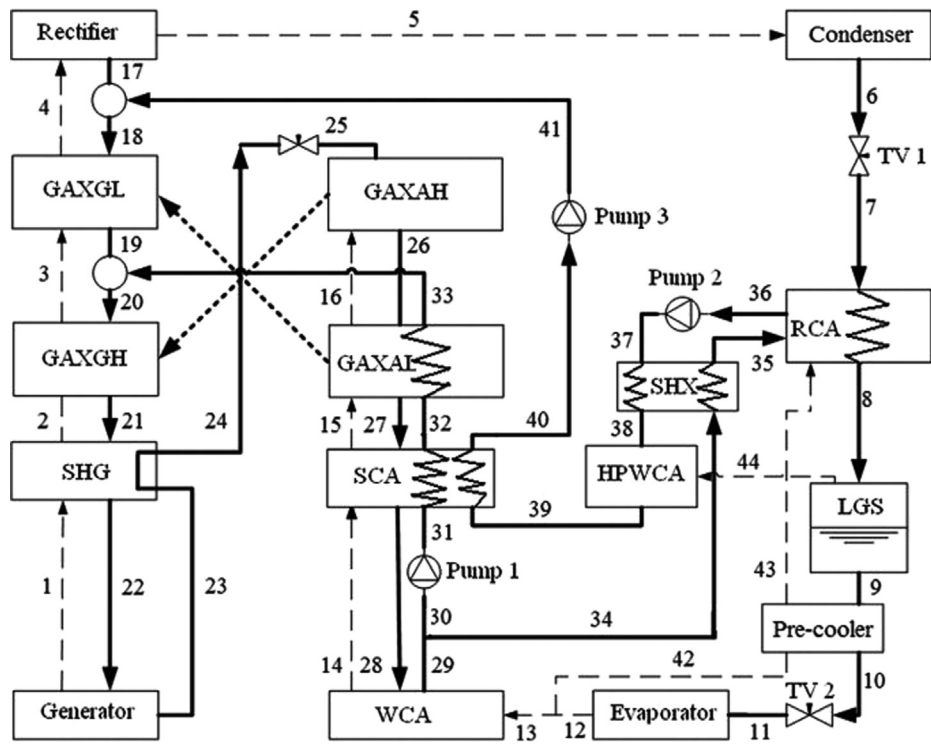

Fig. 14 Schematic of GAX cycle proposed (Reprinted from Shi et al. [98], with permission from publisher).

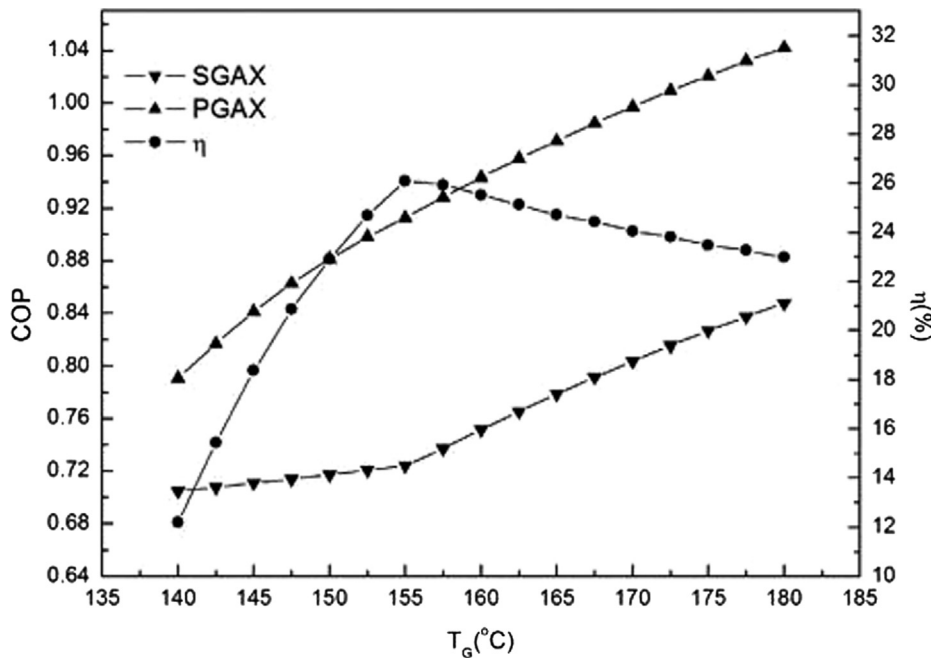

Fig. 15 Variation of COP for simple GAX (SGAX) and proposed GAX (PAGX) cycle (Reprinted from Shi et al. [98], with permission from publisher).

found that the semi-GAX 2 was the most effective cycle for the ambient temperature under 27 °C whereas the semi-GAX 1 showed a better performance working above this temperature.

Some advanced GAX cycles such as WGAX were also proposed to exploit low-grade thermal heat sources such as renewable sources of energy or geothermal energy. Kang et al. [92]

proposed a novel GAX that comprised of two stages of evaporating and absorbing processes for low temperature applications. In another study, Kang et al. [93] disclosed a novel WGAX cycle for exploitation of the waste heat sources. The results revealed that the waste heat source temperature had negligible impact on the performance for an inputted generator

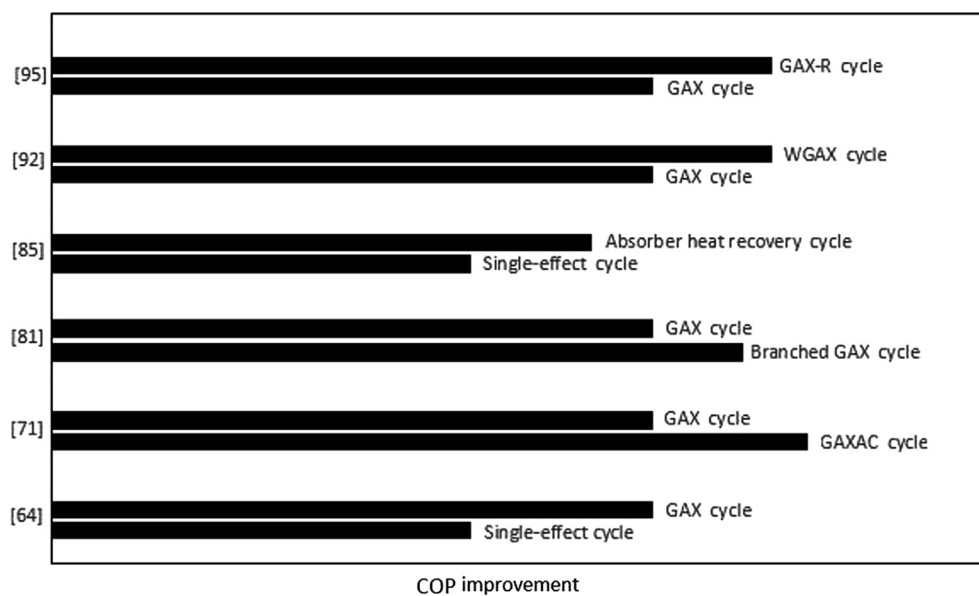

Fig. 16 COP comparison for different absorption heat recovery cycles.

outlet temperature and a greater performance was obtained when the outlet temperature declined to 172 °C. In consequence, the corrosion problem could be addressed by following this novel cycle when a heat source temperature, greater than 200 °C, was applied to the generator. Anan and Erickson [94] designed a heat pump with a cooling capacity of eight ton based on the vapour exchange GAX cycle. The authors concluded that there was a 20% improvement in COP when an air-cooled source of 35 °C was employed to the system. Sabir et al. [95] analytically investigated a new GAX resorption (GAX-R) refrigeration cycle employing a solution of lithium bromide and water. The authors illustrated that the efficiency of the new cycle improved by 1.0, greater than the standard single-effect system but not as high as the GAX cycle due to the limited range of operating conditions. Therefore, it was estimated that wider ranges of water temperatures, mass and heat efficiency could lead to a performance improvement as compared to the simple GAX cycles. The variable effect absorber-generator heat exchanger cycle was proposed by Xu et al. [96] and experimentally investigated by Xu and Wang [97]. This cycle was designed to exploit efficiently the heat source temperature which was not enough for operating a double-effect absorption cooling cycle. However, this source of energy was too high for operating a single-effect cooling cycle. It was observed from the results that the system enjoyed a better performance compared to other cycles working under similar operating conditions. The numerical and experimental results demonstrated that the system performance experienced an increase from 0.7 to 1.08 when the thermal source temperature in the desorber varied from 95 °C to 120 °C. Shi et al. [98] proposed an advanced GAX absorption refrigeration cycle demonstrated in Fig. 14.

The proposed novel GAX cycle was able to exploit low-grade absorption heat, which was impossible for a standard GAX cycle to be operated with and consequently make additional refrigeration. In contrast to the standard GAX cycle, the simulated results illustrated that the proposed cycle could operate suitably at much lower generation and evaporation

temperatures and its COP enhanced by 20%, Fig. 15. Du et al. [99] conducted an examination on maximum internal heat recovery of a mass-coupled two-stage H₂O-NH₃ absorption cooling system by pinch technology for improving the effectiveness in order to widen its practicals. The result demonstrated that the performance of the machine enhanced by 14.5% and 34.1% under the investigated freezing conditions as compared to the basic two-stage absorption cooling cycle.

Fig. 16 presents various heat recovery cycles developed to increase the energy performance of absorption refrigeration systems. GAX cycle is an effective heat recovery cycle that enhances the performance of basic absorption cycle significantly. In comparison to the basic GAX cycle, greater energy performance is obtained with the branched GAX cycle. Another advantage of the branched GAX cycle is its lower generator temperature requirement to operate the cycle, as compared to a standard GAX cycle. In addition, WGAX cycle is particularly designed to exploit low-temperature thermal heat sources (e.g., solar energy) and the results reveal the higher performance of the new system over a basic GAX cycle. As a promising alternative to basic GAX cycle, the absorber heat recovery cycle offers improved COP but rather could operate under a limited range of working conditions due to the crystallization problem. Tables 2 also summarises some studies on various forms of absorption heat recovery cycles discussed in the sub-section 3–2 (see Fig. 17).

4. Improvement of absorption structures and mechanism

4.1. Operating fluid pairs

An appropriate pair of absorbent (sorber) and absorbate (refrigerant) is of great importance in the absorption cooling machine as the efficiency is considerably influenced by the thermodynamic properties of the solution. The followings shall be considered when choosing an appropriate working fluid pair in an absorption cooling system [100]:

Table 2 Summary of some studies on different types of absorption heat recovery cycles.

Cycle type	Working fluid	COP	Remarks	Ref.
GAX	NH ₃ -H ₂ O	–	Appropriate for residential and light commercial	[63]
GAX	NH ₃ -H ₂ O	0.776	There was a relatively 32% increase in the COP in comparison with the single effect	[64]
GAX	NH ₃ -H ₂ O	0.68	The designed chiller was more suitable for a large home or small commercial application	[65]
GAX	NH ₃ -H ₂ O	0.74–0.82	Multi-modes GAX cycles analysed, case 1 produced the largest performance, from the hot water supply viewpoint	[68]
HGAX	NH ₃ -H ₂ O	1.506	Hybrid GAX cycle produced greater performance compared to the traditional GAX cycle	[72]
HGAX	NH ₃ -H ₂ O	1.24	The COP of HGAX cycle enhanced by 24% compared to the simple GAX cycle	[70]
Branched GAX	NH ₃ -H ₂ O	–	The cycle COP improved by 20% in comparison with the simple GAX cycle	[75]
Branched GAX	NH ₃ -H ₂ O	1.174	The COP enhanced considerably from 1.11 for the basic GAX cycle to 1.174	[76]
Poly-branched GAX	NH ₃ -H ₂ O-LiBr	0.85	The cycle produced 1.25–1.9 times higher COP values compared to a basic GAX cycle	[78]
Branched GAX	NH ₃ -H ₂ O	–	There was almost 20% increase in the cycle COP compare to the standard GAX cycle	[79]
Branched GAX	NH ₃ -H ₂ O	0.8–1.4	The COP improved by 14.6% by designing the branched GAX cycle. The COP of branched cycle heavily depended on the condenser temperature.	[81]
Absorber heat recovery	NH ₃ -H ₂ O	–	The cycle performance enhanced by 10% comparing the standard GAX	[82]
Absorber heat recovery	H ₂ O-NH ₃ , NaSCN-NH ₃ , LiNO ₃ -NH ₃	0.2–0.8	COP improved further while using NaSCN and LiNO ₃ -NH ₃ compared to H ₂ O-NH ₃	[84]
Advanced GAX (WGAX cycle)	NH ₃ -H ₂ O	–	Recommended to decrease the generator exit temperature and possible using waste heat sources	[93]
GAX-R	H ₂ O-LiBr	–	The cycle performance was superior to standard absorption and resorption cycles but inferior to a double effect or standard GAX	[95]
Novel GAX	NH ₃ -H ₂ O	–	The proposed cycle COP improved by 20% compared to the standard GAX cycle	[98]

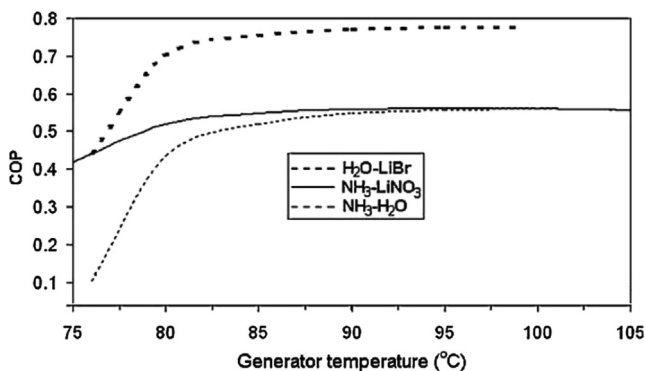

Fig. 17 Variation of COP with the generator temperature for three different working pairs (Reprinted from Karamangil et al. [104], with permission from publisher).

- i. Large latent heats of concentration and vaporization for the refrigerant inside the absorbent;
- ii. Favorable thermodynamic properties such as viscosity, diffusive coefficient, and conductivity; and
- iii. Chemical stability, environment-friendliness, and cost-effectiveness.

Among various working fluid pairs used in absorption systems, H₂O-NH₃ and LiBr-H₂O mixtures represent the most common pair due to their significant thermodynamic properties. The NH₃-H₂O system is frequently used for residential and light commercial refrigeration applications where lower

temperatures are needed, while the LiBr-H₂O system is widely employed for large commercial cooling applications where intermediate temperatures are required.

Researchers in [101,102] reported that the limited properties of LiBr-H₂O are the most significant reasons that prevents applying the lithium bromide-water solution for the refrigeration conditions below 0°C. Kim and Ferreira [103][Kim, 2008 #203] and Gomri [50] discussed that the system efficiency improved further by using LiBr-H₂O as compared to the use of H₂O-NH₃ under the same evaporation temperature. Karamangil et al. [104] executed a numerical investigation to analyse the influence of three different working fluids on the energy proficiency of a single-stage absorption refrigeration machine. The system using the H₂O-LiBr working fluid demonstrated the highest performance. However, the system was just able to work in a limited range of the generator temperature due to the crystallization problem. Among the working pairs, NH₃-LiNO₃ was the most appropriate solution when the system had a tendency to operate at low generator temperatures, less than 75 °C.

Researches also carried out further investigations to analyse the influence of other working fluid pairs and their thermodynamic properties on the system efficiency. The performance of absorption cycles employing three various solutions including NH₃-H₂O, NH₃-LiNO₃ and NH₃-NaSCN was analysed in [105,106]. The results revealed that the highest performance was obtained by employing NH₃-NaSCN cycle while the NH₃-H₂O cycle had the lowest COP for the generator temperatures more than 80 °C. The influence of H₂O-NH₃ and NH₃-LiNO₃ on the system COP was analysed by Kaushik and Kumar [107] in a two-stage absorption cooling cycle. The

results revealed that the cycle with $\text{NH}_3\text{-LiNO}_3$ led to produce higher COP in comparison to that with $\text{H}_2\text{O-NH}_3$.

Iyoki and Uemura [108] used a ternary mixture of $\text{H}_2\text{O-LiBr-LiNO}_3$ as a second option of working fluid pair to the conventional binary mixture of $\text{H}_2\text{O-LiBr}$ with greater performance and less corrosivity. Cai et al. [109] performed an experimental study to examine the efficiency of a single-effect absorption machine cooled with air. Two different kinds of working pairs including $\text{NH}_3\text{-LiNO}_3$ and $\text{NH}_3\text{-NaSCN}$ were used. The system using $\text{NH}_3\text{-NaSCN}$ provided the COP values between 0.20 and 0.35 which were greater than the system efficiency obtained with $\text{NH}_3\text{-LiNO}_3$ at the similar working conditions. The experimental outcomes obtained in this investigation were very useful to develop a better absorption refrigeration system employing $\text{NH}_3\text{-salt}$. Patel et al. [110] conducted a work to study the performance of a single-effect absorption refrigeration system when two working pairs were employed under similar operating conditions. The results illustrated that the system performance improved more considerably while applying $\text{LiCl-H}_2\text{O}$ working pair rather than using the mixture of $\text{LiBr-H}_2\text{O}$. Zhu, and Gu [111] analysed thermodynamically a $\text{NH}_3\text{-NaSCN}$ single-effect absorption cooling machine. Their simulated results revealed that the use of $\text{NH}_3\text{-NaSCN}$ mixture yielded a COP development by 10% as compared to the system COP using ammonia/ H_2O as a conventional mixture. Recently, She et al. [112] presented a new absorption refrigeration system operated by low-grade thermal heat sources. The cycle consisted of a low-pressure sub-cycle employing a solution of LiBr-water with lower vapour pressure and a high-pressure sub-cycle using LiCl-water with higher vapour pressure. Three different modes relating to the utilization of heat source including two parallel mode heat sources and a serial mode heat source were studied. Performance comparisons were made among the three modes and the conventional double-stage absorption cooling cycle using the mixture of $\text{LiBr-H}_2\text{O}$. The results showed that the proposed system was able to provide a better performance.

Won and Lee [113] studied a double-effect absorption cooling cycle employing a new working pair of $\text{H}_2\text{O-LiCl}$ and compared it with the cycle using the $\text{H}_2\text{O-LiBr}$ conventional solution. It was concluded that the employment of $\text{H}_2\text{O-LiCl}$ produced higher performance for the system than the $\text{H}_2\text{O-LiBr}$ mixture. In another study, Won et al. [114] executed a simulation investigation on a double-effect absorption cooling cycle employing a ternary mixture of $\text{H}_2\text{O-LiBr-LiSCN}$ and compared the system COP when two other pairs including $\text{H}_2\text{O-LiBr}$ and $\text{H}_2\text{O-LiCl}$ were employed. The authors reported that the system applied the $\text{H}_2\text{O-LiBr-LiScN}$ solution showed a higher performance than that used $\text{H}_2\text{O-LiBr}$ and $\text{H}_2\text{O-LiCl}$ separately. The results revealed that the system COP improved by 3% as compared to the system using $\text{H}_2\text{O-LiBr}$. Lee et al. [115] proposed a quintuple mixture of $\text{H}_2\text{O-LiBr-LiNO}_3\text{-LiI-LiCl}$ (mole ratio of $\text{LiBr:LiNO}_3\text{:LiI:LiCl} = 5:1:1:2$) as the solution in a double-effect absorption system in serious flow scheme. Interestingly, no crystallization issue was observed in the air-cooled absorption machine by using this proposed solution. Cai et al. [116] examined the efficiency of a double effect absorption system using $\text{NH}_3\text{-NaSCN}$. The system COP increased by 10–15% as compared to the system using $\text{NH}_3\text{-LiNO}_3$ when the evaporator temperature changing between $-10\text{ }^\circ\text{C} < T_{\text{eva}} < 5\text{ }^\circ\text{C}$. Nevertheless, the system using $\text{NH}_3\text{-LiNO}_3$ was more competitive as

compared to that with $\text{NH}_3\text{-NaSCN}$ in low evaporating temperature conditions, $T_{\text{eva}} \leq -15\text{ }^\circ\text{C}$.

Iyoki and Uemura [117] conducted a theoretical analysis to investigate the influence of a quaternary mixture of ($\text{H}_2\text{O-LiBr-ZnCl}_2\text{-CaBr}_2$) on the system performance. The results revealed that the quaternary mixture provided a greater performance as compared to the binary mixture of water-lithium bromide. Sun [118] executed a numerical investigation to analyse the influence of using three different working fluid pairs including NH_3 as the refrigerant with H_2O , LiNO_3 and NaSCN as the absorbents on the efficiency of a single-effect absorption refrigeration system. He observed that the mixture of ammonia with LiNO_3 and NaSCN were appropriate alternatives to replace the conventional solution $\text{NH}_3\text{-H}_2\text{O}$ in the single effect absorption system. Moreover, $\text{NH}_3\text{-NaSCN}$ cycle operated relatively greater than the $\text{NH}_3\text{-LiNO}_3$ cycle, from the performance point of view. Bourouis et al. [119] proposed a quintuple fluid mixture of $\text{H}_2\text{O} + \text{LiBr} + \text{LiI} + \text{LiNO}_3 + \text{LiCl}$ for air-cooled absorption air-conditioning systems. The proposed mixture demonstrated a significantly greater solubility and less corrosive than the conventional working fluid $\text{H}_2\text{O-LiBr}$. Thus, the new mixture was more appropriate than the water-lithium bromide solution especially for available high and low temperatures in the absorber/condenser and in the generator, respectively. In consequence, air-cooled absorption systems using the proposed quintuple mixture could be operated by low-grade heat sources. NaOH was an important chemical compound added to the solution of $\text{H}_2\text{O-NH}_3$ in absorption cycles to separate efficiently ammonia in the desorber and to lessen operating temperature and rectification wastages. In this respect, Steiu et al. [120] simulated the cycle using some experimental data to obtain thermodynamic properties. It was indicated that the COP increased by a factor of one-fifth with a conventional solution of ammonia and water under similar operating conditions and employing a HO separation proficiency for NaOH .

Conventional absorption refrigeration cycles using working pairs such as $\text{H}_2\text{O-NH}_3$ are operated by heat resources of around $70\text{--}120\text{ }^\circ\text{C}$ for cooling and refrigeration to less than $0\text{ }^\circ\text{C}$. In recent years, absorption refrigeration systems operated with low-grade thermal sources like solar energy have been considerably developed. In this respect, some new working pairs such as TFE-TEGDME were then proposed as the potential alternative using in the absorption systems powered by low temperature heat sources [14,121,122]. Arivazhagan et al. [123] performed simulation investigations on a half-effect R134a-DMAC absorption cooling system driven by solar energy. It was observed that the system provided a higher performance as compared to a half-effect cycle using $\text{NH}_3\text{-H}_2\text{O}$ for low-grade thermal sources. Karno and Ajib [124] performed a theoretical examination of an absorption refrigeration system employing a novel mixture of $\text{C}_3\text{H}_6\text{O-ZnBr}_2$ with low generator temperatures ranged from 47 and $60\text{ }^\circ\text{C}$. The result revealed that $\text{C}_3\text{H}_6\text{O-ZnBr}_2$ was a very suitable working fluid mixture for low-temperature applications such as solar systems due to its impressive thermodynamic properties. In another study, an absorption refrigeration system driven thermally with solar energy was analysed by Moreno-Quintanar et al. [125]. A binary mixture of $\text{NH}_3\text{-LiNO}_3$ as well as a ternary mixture of $\text{NH}_3\text{-LiNO}_3\text{-H}_2\text{O}$ were employed. The results demonstrated that the efficiency of the system improved by 24% with the use of the ternary mixture

when the system operated by low-level heat energy sources. Donate et al. [126] employed a solution of LiBr with CHO_2 and CH_3CO_2 as alternative absorbents. The results indicated that the application of new absorbent mixture of organic salt in lithium bromide led to an improvement in the system performance due to a reduction in some properties like the vapour pressures, latent heat of absorption and crystallization temperature. More recently, a detailed thermodynamic analysis was carried out by Arshi and Sudharsan [11] on a single-effect absorption cooling machine applying a quaternary fluid mixture of $\text{H}_2\text{OLiBr-Li-LiNO}_3\text{-LiCl}$. It was concluded that the cycle with the proposed combination was able to work under wider range of operating temperature and to enjoy a greater performance as compared to the conventional combination of $\text{H}_2\text{O-LiBr}$ employing in the system. Therefore, the system was more suitable for air-cooled application without crystallization. Gao et al. [127] investigated an air-cooled absorption R290/oil refrigeration cycle driven by waste heat. Their results demonstrated that using R290/oil working pair resulted in a significant improvement in the system performance. Oibricht et al. [128] investigated numerically a single-stage absorption chiller using lithium bromide by means of alcoholic additives with a cooling capacity of 5 kW. The results revealed that adding a small amount of additive into the aqueous LiBr solution caused a considerable increase in the CC and COP as they improved by 83% and 31%, respectively. It was observed from the results that the same cooling capacity was produced with a smaller size of the solar collectors while there was an enhancement in the COP. The obtained results led to a significant reduction in costs along with an increase in diffusion of domestic-scale solar powered absorption chillers.

Over the last few years, several researchers investigated the influences of nanoparticles application into the working solutions and particularly in $\text{NH}_3\text{-H}_2\text{O}$ to make an increment in the system performance. In fact, addition of nanoparticles into the working pair leads to an easier and faster separation of water vapour from the NH_3 vapour. Yang et al. [129] executed an experimental work of a selection of 20 different kinds of nanoparticles mixed pair with 10 types of dispersants applied to the $\text{NH}_3\text{-H}_2\text{O}$ absorption system to investigate the diffusion stability of interruption. In another work, Yang et al. [130] experimentally analysed the influence of adding three different nanoparticles in the mixture of $\text{NH}_3\text{-H}_2\text{O}$ on the heat and mass transfer rate in the system. The results indicated that three main factors including the content of surfactant and nanoparticles, the interaction between surfactant and nanoparticles, and the diffusion type affected considerably the viscosity of nanofluid. Sözen et al. [131] examined the impact of heat recovery approach in a single-effect cycle using $\text{NH}_3\text{-H}_2\text{O}$ solution with nanoparticles of alumina (Al_2O_3) on the propagation absorption system. The results demonstrated that the mixture of nanoparticles into the fluid led to a considerable enhancement in the heat transfer, the segregation of NH_3 in the vapour from $\text{NH}_3\text{-H}_2\text{O}$, and consequently improvement of the cooling effect. Jiang et al. [132] performed an experimental work to investigate the effect of different quantity of TiO_2 nanoparticles on the COP of an absorption system using $\text{NH}_3\text{-H}_2\text{O}$ working fluid. Experimental results revealed that the TiO_2 nanoparticles exerted a significant influence on the performance as the COP increased by 27%. It is observed from Fig. 18 that the mixture of 0.5 wt% TiO_2 and the 0.02 wt%

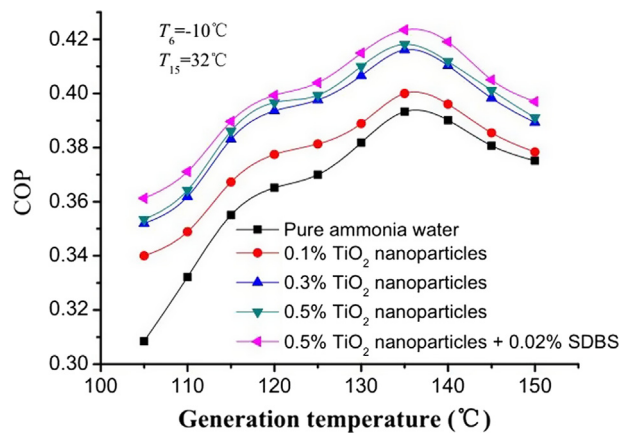

Fig. 18 The COP of absorption system with different mass fractions of TiO_2 nanoparticles under different generation temperatures (Reprinted from Jiang et al. [132], with permission from publisher).

SDBS had the most considerable influence on the COP enhancement compared to other nanofluid.

Fig. 19 illustrates the effect of various working pairs on the COP improvement in different works. As it is observed, $\text{LiBr-H}_2\text{O}$ and $\text{NH}_3\text{-H}_2\text{O}$ are the most common pairs used in the absorption cooling systems. It is important to note that application of $\text{LiBr-H}_2\text{O}$ in the system provides a higher performance although the system could just work in a limited range of generator temperature due to the crystallization problem. As a result, as a working fluid pair, the $\text{LiBr-H}_2\text{O}$ is mainly used for large commercial cooling applications where moderate generator temperatures are required. On the other hand, the $\text{NH}_3\text{-H}_2\text{O}$ solution is widely applied for residential and light commercial refrigeration applications where lower generator temperatures are needed. The chart reveal that the

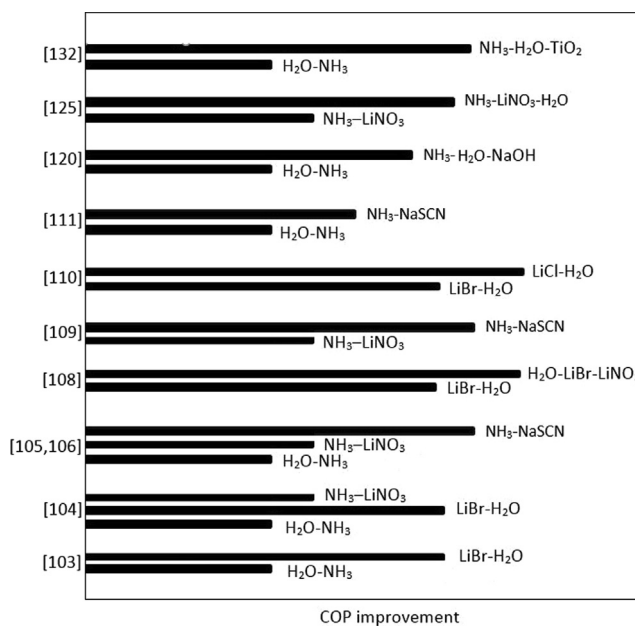

Fig. 19 COP comparison for single-effect absorption systems using various kinds of working pairs.

Table 3 Summary of the characteristics of various working fluid pairs.

Cycle type	Working pair (refrigerant + absorbent)	Remarks	Ref.
Two stage	NH ₃ -LiNO ₃	System with NH ₃ + LiNO ₃ operated by lower generation temperature and provided higher COP than NH ₃ -H ₂ O	[107]
Single effect	NH ₃ -LiNO ₃ and NH ₃ -NaSCN	Cycle employing NH ₃ -NaSCN produced better performance	[109]
Single effect	LiCl-H ₂ O	Greater performance than LiBr-H ₂ O	[110]
Single effect	NH ₃ -NaSCN	Cycle COP raised by 10% compared to the NH ₃ -H ₂ O	[111]
Double effect	H ₂ O-LiCl	Better performance obtained than the cycle with H ₂ O-LiBr	[113]
Double effect	H ₂ O-LiBr-LiSCN	The system illustrated higher performance with a ternary mixture	[114]
Double effect (Series mode)	H ₂ O-LiBr-LiNO ₃ -Li-LiCl	No crystallization problem, better performance and lower generation temperature	[115]
Double effect (Series mode)	NH ₃ -NaSCN-NH ₃ -LiNO ₃	Larger performance with NH ₃ -NaSCN than NH ₃ -LiNO ₃	[116]
Single effect	H ₂ O-LiBr-ZnCl ₂ -CaBr ₂	Quaternary mixture produced greater performance than the binary of H ₂ O-LiBr	[117]
Single effect	NH ₃ -H ₂ O-NH ₃ -LiNO ₃ -NH ₃ -NaSCN	System performance with NH ₃ -NaSCN was better than that with NH ₃ -LiNO ₃	[118]
Single effect	H ₂ O-LiBr-Li-LiNO ₃ -LiCl	Less corrosivity, lower temperature in generator was required, recommended for systems operated by low-temperature heat sources	[119]
Single effect	NH ₃ -H ₂ O-NaOH	Improving the ammonia separation in the generator, lower generation temperature, COP enhanced by 20% compared to NH ₃ -H ₂ O	[120]
Half effect	R134a-DMAC	Performance increased significantly with the R134a-DMAC for the half effect cycle compared to NH ₃ -H ₂ O	[123]
Single effect	C ₃ H ₆ O-ZnBr ₂	The system was appropriate for working at low generator temperatures (47–60 °C)	[124]
Single effect	LiBr-NaK	The efficiency improved marginally; lower generation temperature required	[126]
Single effect	H ₂ O-LiBr-Li-LiNO ₃ -LiCl	Provided system to work under wider range of operating temperatures, enjoyed a better performance compared to H ₂ O-LiBr	[11]
Single effect	NH ₃ -H ₂ O-TiO ₂	The cycle COP improved by 27% with adding TiO ₂ particles to the working pair	[132]

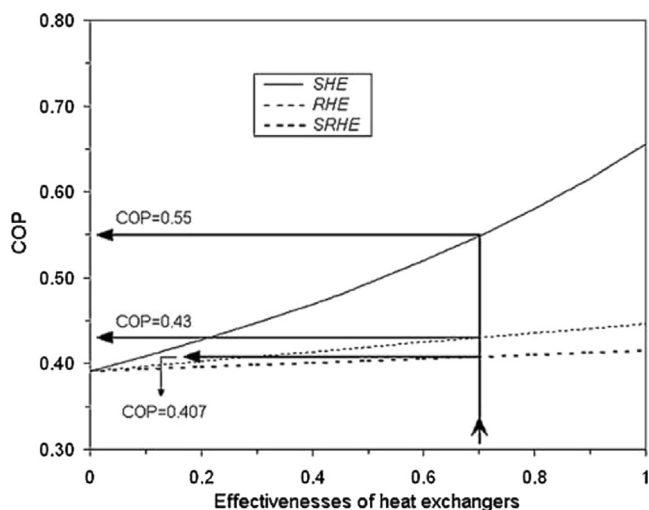

Fig. 20 Variation of COP with effectiveness of solution, refrigerant, and solution-refrigerant heat exchangers (Reprinted from Karamangil et al. [104], with permission from publisher).

highest COP was obtained by using NH₃-LiNO₃ as the working fluid pair when the available heat source was of low temperature (greater than 75 °C). In comparison, the NH₃-NaSCN was the most effective solution when a high-temperature heat source was available for vapor generation in the desorber. As a ternary mixture, LiNO₃ was found to serve as a very effective additive with both H₂O-LiBr and

NH₃-H₂O. In contrast to LiBr-H₂O, a greater COP was achieved by applying the ternary mixture of H₂O-LiBr-LiNO₃ in the system with less corrosivity. In addition, the system COP improved significantly by using the NH₃-LiBr-LiNO₃ as a ternary mixture, as compared to the binary mixture of NH₃-H₂O. In order to enhance the COP of the NH₃-H₂O absorption system, NaOH particles were added to the mixture, leading to 20% increase in the system performance. Particular nanoparticles have also been used to improve the system performance with conventional working fluid pairs. In this regard, the TiO₂ nanoparticles were successfully used to enhance the system COP with a mixture of NH₃-H₂O-TiO₂ as the working fluid.

In order to have a better comparison between various working fluids used in absorption systems, a summary of studied working pairs are presented in Table 3. It is concluded from the table that the water is the main refrigerant in most working fluid pairs due to its excellent advantages such as zero environmental problems. It is also witnessed from the table that the influence of different working fluids on the energy performance are analysed mostly in single-effect cycles compared to other absorption cycles.

4.2. Combined systems (Added components and sub-components)

Investigations on absorption refrigeration systems have demonstrated that the system design, material properties, and the sub-components are the main factors affecting the

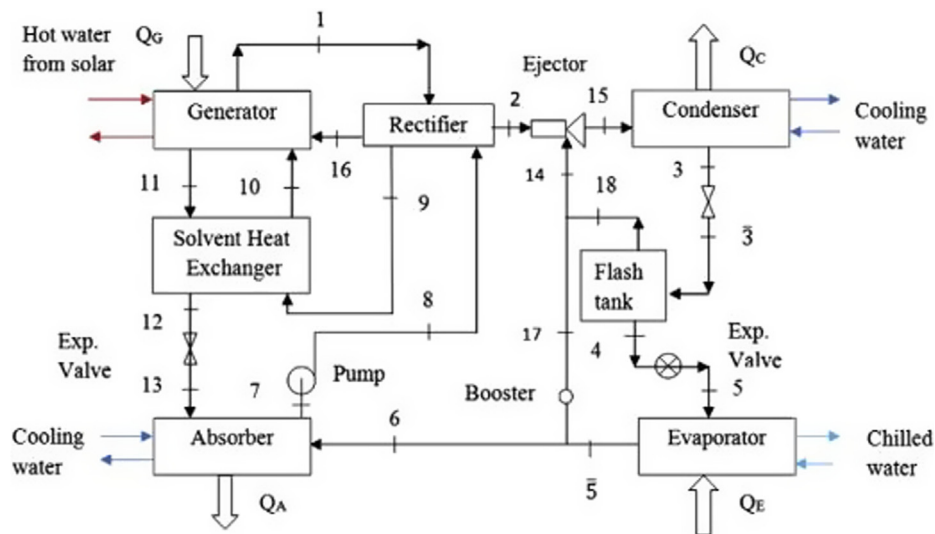

Fig. 21 Combined flash tank-absorption-ejector refrigeration cycle proposed by Sirwan (Reprinted from Sirwan [138], with permission from publisher).

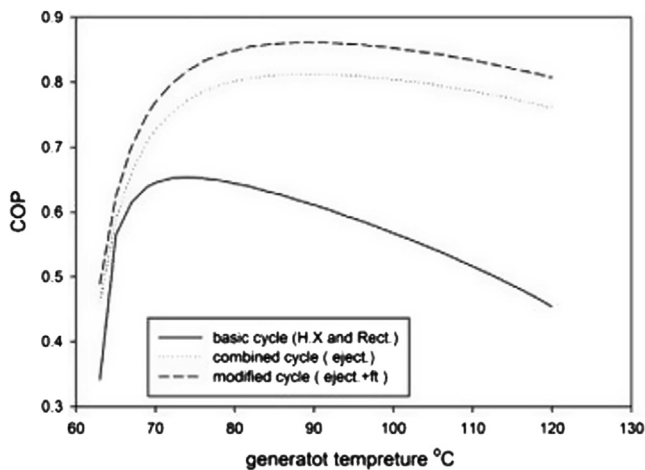

Fig. 22 Variation of COP versus the generator temperature for basic absorption cycle, combined absorber-ejector cycle and combined flash tank-absorber-ejector cycle (Reprinted from Sirwan [138], with permission from publisher).

system performance. The subcomponents and supported components have effectively influenced the standard single-effect absorption cycles to achieve enhanced system performance. Effects of important subcomponents (e.g., solution and refrigerant heat exchangers, flash tank, distillation column, and ejector) on the absorption system efficiency are discussed in the following.

4.2.1. Refrigerant and solution heat exchangers

Solution heat exchanger (SHE), placed into the solution circuit between the absorber and the generator, is an essential subcomponent of an absorption cycle that contributes to efficient recovery of the thermal energy of the concentrated solution returning from the generator toward the absorber. The recovered energy is then applied to preheat the diluted solution leaving the absorber before entering the desorber. This reduces the

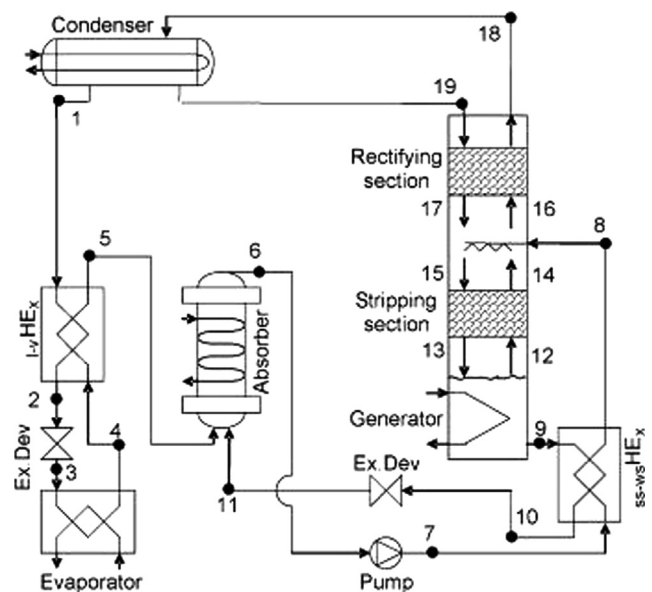

Fig. 23 Schematic diagram of the absorption system and distillation column (Reprinted from Fernández-Seara and Sieres [142], with permission from publisher).

heat requirement of the generator, leading to improved COP. Aphornratana [133] conducted an experimental work and he indicated that the COP experienced a significant rise by three-fifth by adding a SHE into the system. Sozen [134] performed an investigation to observe the influence of heat exchangers on the efficiency in a standard absorption refrigeration system using $\text{H}_2\text{O-NH}_3$. He reported that the system performance was considerably influenced by adding a SHE whereas using both refrigerant heat exchanger (RHE) and SHE had no significant effect on the efficiency. In another study, Koehler et al. [135] found that the SHE played a prominent role in enhancing the system performance while the RHE was of lesser importance for a $\text{H}_2\text{O-LiBr}$ cycle. The influence

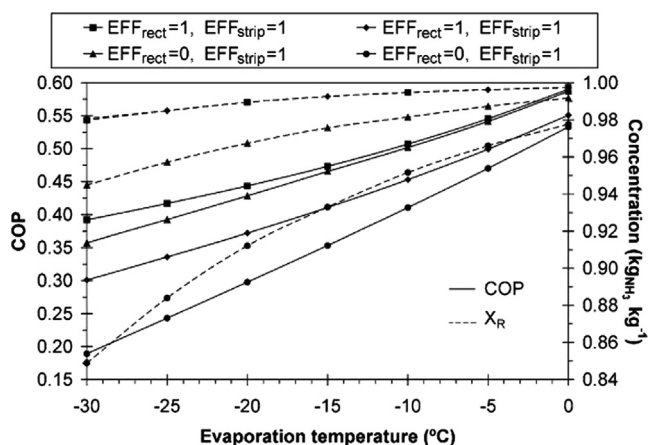

Fig. 24 Variation of COP versus the evaporation temperature in the presence of distillation column (Reprinted from Fernández-Seara and Sieres [142], with permission from publisher).

of the solution and refrigeration heat exchangers, as well as operating conditions on the COP of a single effect H_2O -LiBr was numerically investigated by Kaynakli, et al. [12]. It was concluded from the results that the influence of solution heat exchanger on the parameters was more significant than that of refrigerant heat exchanger. While the former caused an increase of 44% in the COP, there was just almost 3% rise in the system COP by the latter application. Karamangil et al. [104] performed a work to analyse the influence of impressiveness of SHE, RHE and solution-refrigerant heat exchanger on the system COP. As it is observed from Fig. 20, the SHE had the most considerable effect on the performance as the COP improved 66% by using the SHE. However, there was a minimal increase in the system performance by employing the both RHE and SRHE (see Fig. 21).

4.2.2. Flash tank

As another sub-component of an absorption refrigeration system, the flash tank is usually combined with multi-pressure systems to improve the cooling capacity (CC) and COP. In fact, one can obtain enhanced system energy efficiency and CC when a flash tank is combined with a two-stage cycle through supplying the evaporator with liquid [136,137]. Sirwan et al. [138] proposed a new design of a single-effect refrigeration system in which a flash tank was set up between the evaporator and condenser to increase CC within the evaporator, shown in Fig. 22 (see Fig. 23).

It was observed from the results that the combined system as comprised of both the ejector and flash tank had the greatest COP while the lowest performance was obtained by the basic absorption cycle. When it comes to the combination of an ejector with the absorption cooling cycle, performance improvements can be obtained by integrating a flash tank into the ejector-equipped cycle. In recent years, Abed et al. [139] examined an integrated ejector-flash tank NH_3 - H_2O absorption refrigeration system in order to provide a higher performance for the system. In another work, Sirwan et al. [140] demonstrated that combining a flash tank to an integrated absorption-ejector cooling cycle led to an enhancement in the efficiency of the system.

4.2.3. Distillation column

As an important element of any absorption refrigeration cycle, the distillation column simultaneously provides for heat and mass transfer phenomena through the two-phase, two-component mixture of NH_3 - H_2O . The primary role of this component is to provide high-purity ammonia vapor, without which the water content would be gradually collected in the evaporator, lowering the system COP. Anand and Erickson [141] investigated the effect of distillation column of a single effect NH_3 - H_2O absorption machine on the system performance. Fernández-Seara and Sieres [142] carried out an investigation to analyse the effect of the ammonia purification process on the effectiveness of the NH_3 - H_2O absorption refrigeration system in terms of the column efficiencies and reflux ratio. The authors conducted their analysis for a wide range of operating conditions including both air and water-cooled systems for different applications by changing the evaporation temperature.

Fig. 24 illustrated that the presence of a distillation column was necessary in the application of low evaporation temperature; otherwise, the system efficiency would be degraded. On the other hand, a distillation column was not necessarily required in the application of high evaporation temperature. The authors also emphasized the significance of purification process in applications with high absorption and condensation temperatures as observed in air-cooled systems. In another work, Sieres and Fernández-Seara [143] performed an experimental investigation to analyse the effect of ammonia rectification on the performance of the absorption refrigeration system. The results revealed that the system efficiency enhanced by using the stripping and rectifying sections.

Darwish et al. [144] performed a work to analyse the efficiency of a Robur absorption refrigeration system with a

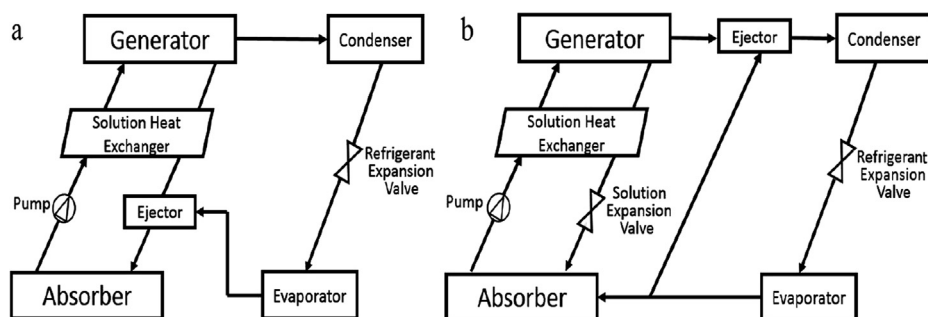

Fig. 25 Schematic of combined ejector-absorption cycle; (a) first configuration, (b) second configuration.

mixture of ammonia and water. It was observed that the effectiveness of the separator as a mass transfer unit exerted a substantial influence on the system performance as it experienced an increase of 15% by raising the quantity of stripping stages of the separator. Moreover, the system efficiency was obtained to be at optimum when the six steps of mass transfer were adopted. Aguilar and Simoes-Moreira [145] presented a work to examine the influence of a distillation column with segmented weir sieve-tray for a NH_3 -water absorption refrigeration system with 17.58 kW capacity. The result revealed that the vapour concentration enhanced by 51% through installing the stripping section inside the generator. However, other parts such as the enrichment and rectifier provided a minimal increase in the vapour concentration by 1.5% and 2.2%, respectively.

4.2.4. Ejector

Ejector refers to a sub-component integrated into the absorption refrigeration systems to increase their energy effectiveness. In a single-effect cycle, the two-pressure configuration can be converted to a triple-pressure combined ejector-absorption cycle by setting up an ejector in the cycle. This makes the system operate at higher absorber and condenser temperatures and lower generator temperature and circulation ratio. A combined ejector-absorption cycles represents a multiple-effect absorption system but with less components. Considering the position of the ejector in the absorption cycle, two types of triple-pressure combined system can be considered: (1) with the ejector situated at the entrance of the absorber at the solution expansion valve to make pressure recovery from the absorber and increasing the mixing of the weak solution with the refrigerant vapor leaving the evaporator (Fig. 25a) [146–151], (2) with the ejector located between the condenser and generator (Fig. 25b) [152–154]. In this type, the ejector is driven by the high-pressure refrigerant vapour coming from the generator leading to an increase in the vaporization of refrigerant and consequently producing higher cooling capacity in the system.

Chen et al. [146] was among the first proposed a novel combined absorber-ejector cycle to analyse the influence of application of an ejector in a single-effect absorption system on the cycle performance. In the cycle, the ejector was replaced by the solution heat exchanger. It was revealed from the results that the performance of the new cycle improved substantially as compared to that of the basic single effect absorption cycle. Sozen and Ozalp [147] investigated an energy and exergy analysis of a combined ejector-absorber cycle employing NH_3 - H_2O working pair. The results illustrated that there was a noticeable improvement in the energy and exergy efficiency, particularly at lower generator temperatures. In addition, the system design dimension could be reduced due to a reduction in circulation ratio causing a decline in the overall cost of the system. Jelinek et al. [149,155] performed similar works in order to study the influence of using an ejector in combined ejector-absorption refrigeration cycles using different working pairs. Vereda et al. [150] numerically performed an investigation of an integrated NH_3 - LiNO_3 ejector-single effect refrigeration system to examine the effect of the ejector geometry on the cycle efficiency. They situated the ejector at the entrance of the absorber in place of the solution expansion valve. In the combined system, the activation temperature

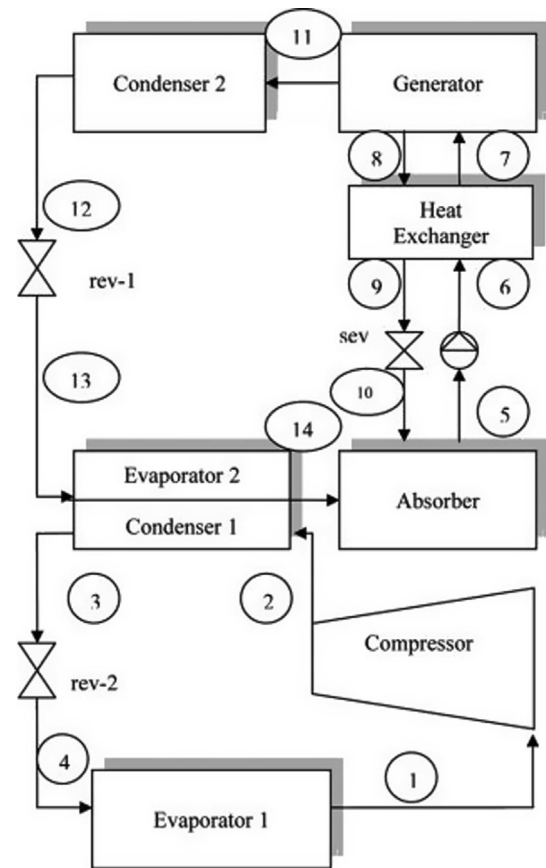

Fig. 26 Schematic of single effect compression-absorption cascade refrigeration cycle (Reprinted from Wang et al. [165], with permission from publisher).

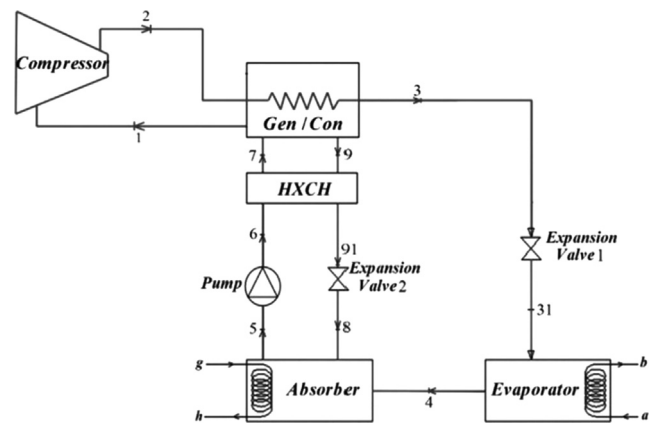

Fig. 27 A schematic diagram of the hybrid single-effect absorption/vapour recompression cycle (Reprinted from Razmi et al. [170], with permission from publisher).

reduced nearly 9 °C as compared to the standard single-effect absorption cycle. In addition, the system was able to work efficiently at moderate temperatures. Garousi Farshi and his colleagues carried out investigations to examine the effect of combining an ejector with a single effect absorption cycle [151] along with a double effect absorption cycle in series flow type [156] on the systems performance at various

operating conditions. The ejector was integrated with a single-effect absorption cycle regarding the first combination and it was applied in the double effect absorption cycle based on the second configuration. In both works, it was observed that the system performance increased significantly in respect to the conventional single-effect and double-effect absorption systems. Sun et al. [152] disclosed a combined LiBr-H₂O ejector-absorber refrigeration cycle in which the ejector was located between the condenser and the generator. The combined cycle was an appropriate design for exploiting waste thermal energy. It was observed that the effectiveness of the new combined system improved by 50% in comparison with a conventional single-effect cycle. Bellos and Tzivanidis [157] conducted an examination to optimize a lithium-bromide water ejector-absorption cooling system driven by parabolic trough solar collectors. They found that the performance of the combined cycle enhanced by 60.9% as compared to the conventional absorption system under the same operating conditions. Moreover, it was found from the optimization that the maximization of the COP achieved when the exergy efficiency of the system was also maximum while demanded collecting area was minimum.

4.2.5. Compressor

All types of the absorption refrigeration systems reviewed in previous sections were variants of the basic absorption cycle with particular subcomponents. A cascade absorption-compression refrigeration system is shown in Fig. 27. It is, indeed, a combination of an absorption cooling subsystem with a mechanical compression subsystem, to which a mechanical compressor is added. A mechanical compressor, like ejector, can be located in different places between main components of a single-effect cycle and a double-effect cycle [158–160], multi-effect cycle [161] and GAX cycle [70,162]. Kairouani and Nehdi [160] studied an absorption-compression refrigeration cycle to make an enhancement in the system efficiency. The results illustrated that the performance of the combined cycle improved by 37–54% as compared to the single-effect absorption refrigeration cycle under the same working conditions. Cimsit and Ozturk [163] numerically simulated a compression-absorption cascade system using water as a refrigerant with the lithium bromide and the ammonia as two conventional absorbents in the high-temperature cycle. They also used some refrigerants such as NH₃, R134a and R410a in the low-temperature cycle. It was observed that the consumption of electrical energy in the cascade cooling cycle reduced by half as compared to the conventional vapour compression refrigeration cycle. Furthermore, the system using LiBr-H₂O illustrated a higher performance as compared to NH₃-H₂O. A vapour compression absorption system with CO₂ as a refrigerant of compression subsystem along with NH₃-H₂O as a refrigerant of absorption subsystem was thermodynamically examined by Jain et al. [164]. Modified Gouy-Stodola equation was applied to determine the optimal condensation temperature of cascade condenser. This led to an improvement in the overall COP and a reduction in the whole irreversibility rate of the system. Wang et al. [165] investigated a NH₃-H₂O absorption-compression hybrid cooling system to enhance the efficiency of the conventional absorption cooling cycle. The proposed cycle enabled to recover the whole condensing heat in order to produce absorbate by raising the quantity of condensation heat with a vapour compres-

or, Fig. 26. The results revealed that there was a substantial reduction (70–80%) in the generation heat temperature. In consequence, the cycle performance almost doubled as compare to the standard absorption refrigeration system (see Figs. 28 and 29).

A cascade absorption-compression refrigeration system could also be effective to improve the system efficiency when a high-grade thermal source of energy is not available to operate a standard absorption cooling system. Moreover, the cascade system is also able to work efficiently when sufficient evaporating temperature is not available to be achieved appropriately [166–169]. Chen et al. [166–168] carried out some studies to investigate the possibility of cascade absorption-compression refrigeration systems working for low-temperature applications. They [167] disclosed a novel absorption/absorption-compression refrigeration system to improve the energy performance of the absorption refrigeration cycle. The results demonstrated that the cooling capacity enhanced by 28% as compared to the single-effect absorption system. The authors in [168] disclosed a modern thermal absorption-compression refrigeration cycle to provide the cooling power which is needed to attain a low temperature of 60 °C. The authors compared their proposed system performance with a two-stage refrigeration system employing NH₃-H₂O solution. They found that the COP of their new cycle was almost two times greater than that of a basic two-stage absorption refrigeration cycle using the same working pair. Razmi et al. [170] performed a research work to analysis an integrated environmentally-friendly hybrid absorption-recompression refrigeration system in which a booster compressor was placed between the generator and condenser of absorption system. The system efficiency improved considerably by adjusting the pressure ratio to optimize the absolute heat transfer between the generator and the condenser coils. Their results indicated that the integrated system performance

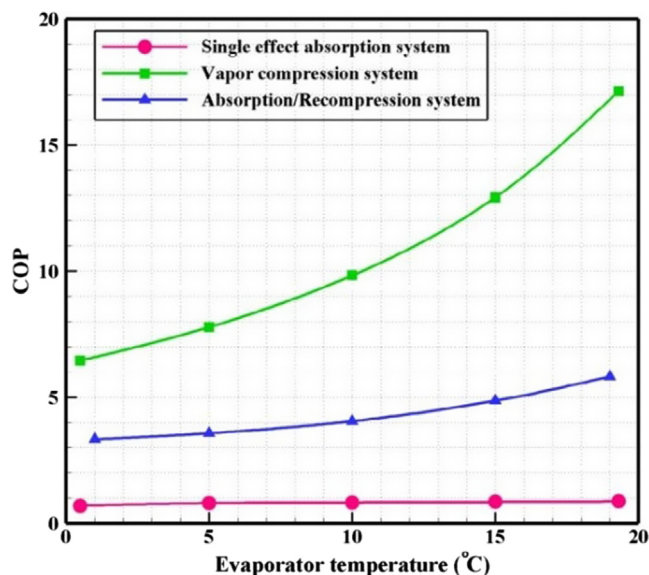

Fig. 28 COP alteration of different systems by changing evaporator temperature (Reprinted from Razmi et al. [170], with permission from publisher).

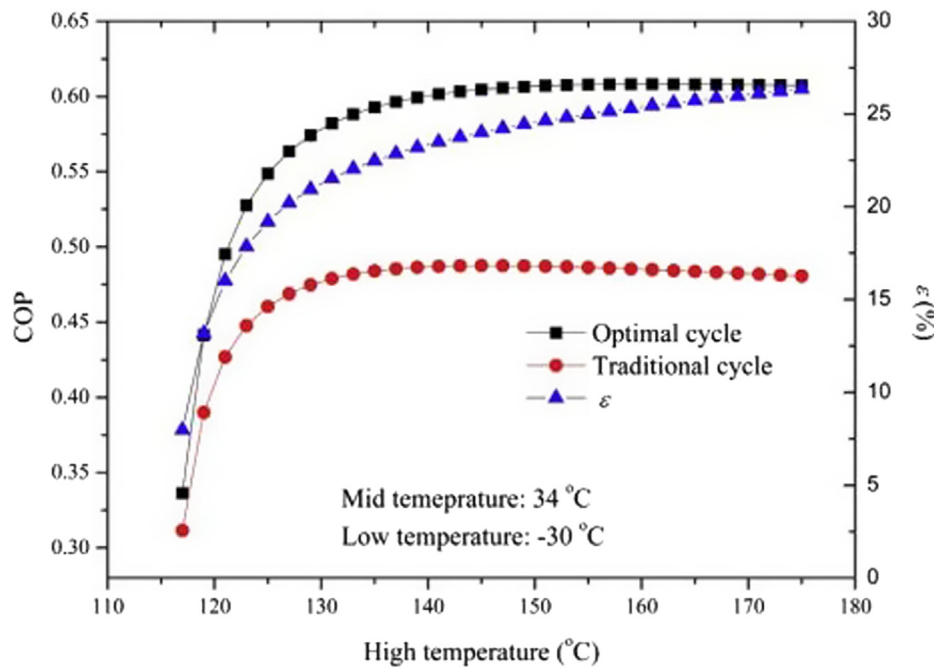

Fig. 29 Variation of COP versus the high generator temperature for optimal cycle and conventional cycle (Reprinted from Du et al. [177], with permission from publisher).

was relatively four times higher than the basic absorption system.

A summary of a number of works studied the influence of various added subcomponents on the system efficiency are given in Table 4.

5. Improvement of operating conditions

The efficiency of an absorption system is also affected by operating parameters including the temperatures of different components, heat source, and chilled and cooling working fluids, the flow rate of the working fluids passing through the components, solution circulation ratio, etc. Extensive research has been performed to study the influence of the operating parameters on the system performance through developing different simulation programs and experimental investigations.

Eisa [171,172], Sun [173], and Chua [174] carried out different investigations to provide thermodynamic analyses of a H₂O-LiBr single-effect absorption refrigeration system. The influence of various operating conditions on the system efficiency was examined. The results showed that the COP improved by increasing the generator and evaporator temperatures while an increase in the absorber and condenser temperatures led to a decrease in the COP. Eisa and Holland [172] experimentally analyzed the influence of variations of the operating conditions on the cycle performance of an absorption LiBr-H₂O cooler. It was found that the generator temperature was the most prominent parameter affecting the performance of the system. In another work, Eisa et al. [171] performed more experiments on Eisa and Holland' system [172] to examine the influence of the temperature variations of other components such as the absorber and condenser temperatures on the system performance. They found that the temperature varia-

tion of the absorber had greater influence on the COP as compared to the condenser. Mostafavi and Agnew [175] performed a simulation analysis to investigate the influence of ambient temperature on the H₂O-LiBr absorption refrigeration system. Sencan et al. [176] executed a study to analyse a single-effect absorption system employing lithium bromide/water mixture for heating and cooling applications under various working conditions. The results revealed that increasing the temperature of the heat source caused an improvement in the cooling and heating performance of the system. Moreover, the efficiency experienced a considerable rise by increasing the chilled water inlet temperature, which led to produce further cooling capacity from the evaporator. Kaynakli and Kilic [12] performed an investigation to examine the influence of working temperatures and heat exchanger effectiveness on the system performance for a single-effect LiBr-H₂O absorption system. It was concluded that the system efficiency enhanced with increment in the evaporator and generator temperatures. However, it experienced a decline with rising the absorber and condenser temperatures. Gomri [50] investigated the influence of different working variables on the performances of three absorption refrigeration systems. For every evaporator and condenser temperature, there was an optimum generator temperature in which the maximum value of performance was obtained. Du et al [177] performed a simulation investigation of an optimal NH₃-H₂O absorption refrigeration system with maximum internal heat recovery by employing method of pinch technology. The optimal cycle operated exactly like the GAX cycle when there was a temperature overlap between the generator and absorber. Some 20% increase in the efficiency of the optimal cycle was observed compared to the conventional absorption cycle under the same operating conditions. Furthermore, the effect on the COP of the optimal

Table 4 Summary of different sub-components integrated with absorption systems.

Added Component	Cycle type	Operating temps. (°C)	Working pair	Remarks	Ref.
Solution heat exchanger	Single effect	–	–	There was 60% increment in the system performance by adding a SHE	[133]
Mixture heat exchanger + Refrigerant heat exchanger	Single effect	$T_e = -20, -10, 0, 10$ $50 < T_g < 130$ $T_c = T_a = 22, 24, 25, 27, 28$	H ₂ O-NH ₃	The system performance was mainly affected by the MHE more than by both the MHE and RHE	[134]
Solution heat exchanger + Refrigerant heat exchanger	Single effect	$T_e = 2, 6$ $60 < T_g < 90$ $T_c = T_a = 30$	H ₂ O-LiBr	The COP enhanced by 44% with the application of SHE and RHE had an increase of only 3% on the COP	[12]
Flash tank + ejector	Single effect	$60 < T_g < 120$ $20 < T_c, T_a < 50$ $-14 < T_e < 14$	NH ₃ -H ₂ O	The COP enhanced considerably by adding a flash tank in the single effect absorption system; Enabled system to operate at higher condenser temperature	[138]
Flash tank	Single effect	$-15 < T_{\text{ambient}} < 5$	–	The system performance improved by 10%	[137]
Distillation column	Single effect	$T_e = -10$ $T_g = 125$ $T_c = T_a = 30$	NH ₃ -H ₂ O	The importance of a distillation column for low evaporation temperature applications; The stripping section had greater influence on the COP than the rectifier part	[145]
Ejector (First combination)	Single effect	$T_e = -10, 0, 10$ $50 < T_g < 130$ $T_c = 25, 30, 35, 40$ $T_a = 30, 35, 40, 45$	NH ₃ -H ₂ O	The COP enhanced by half; Reduction in the circulation ratio by three-fifth leading the decrease in overall cost	[147]
Ejector (First combination)	Single effect	–	NH ₃ -LiNO ₃	Reducing the operating temperature relatively 9C compared to the traditional single-effect cycle; Increasing the performance for intermediate temperature	[150]
Ejector (First combination)	Single effect	$T_e = 0$ $60 < T_g < 120$ $T_c = T_a = 30, 35, 40$	NH ₃ -LiNO ₃ + NH ₃ -NaSCN	Producing larger performance in respect to the single-effect cycle at low generator temperatures	[151]
Ejector (Second combination)	Single effect	$5 < T_e < 15$ $190 < T_g < 220$ $22 < T_c, T_a < 40$	LiBr-H ₂ O	The COP of combined system can be improved by 50% compared to a standard single-effect absorption system;	[152]
Ejector (Second combination)	Double effect (Series mode)	$T_e = 4, 7, 10$ $102 < T_g < 192$ $T_c = T_a = 32, 37, 42$	LiBr-H ₂ O	Reduction in the overall cost of the whole system in comparison to the double effect cycle in series mode	[156]
Compressor	Single effect Double effect	$T_e = -10$ $30 < T_c, T_a < 38$ $107 < T_g < 147$	LiBr-H ₂ O + CO ₂ -R134a	Reduction of 45% in mechanical energy consumption compared to the classical compression cycle; 50% increase in the COP	[158]
Compressor	Single effect	$70 < T_g < 76$ $T_e = -10$ $T_c = T_a = 35$	NH ₃ -H ₂ O + R717, R22, R134a	The COP enhanced by 37–54% in respect to the conventional cycle	[160]
Compressor	Single effect	$T_e = -10$ $T_c = T_a = 40$	LiBr-H ₂ O + NH ₃ -H ₂ O + R134a, R-410A, NH ₃	Considerable reduction in electrical energy consumption compared to conventional compression cycle; Combined system employing LiBr-H ₂ O produced greater performance than that using NH ₃ -H ₂ O	[163]
Compressor	Single effect	$80 < T_g < 120$ $T_c = T_a = 30$ $T_e = -15$	NH ₃ -H ₂ O	The thermal performance of the absorption-compression refrigeration system improved 17% compared to that of conventional absorption system for the generation temperature of 100C.	[166]

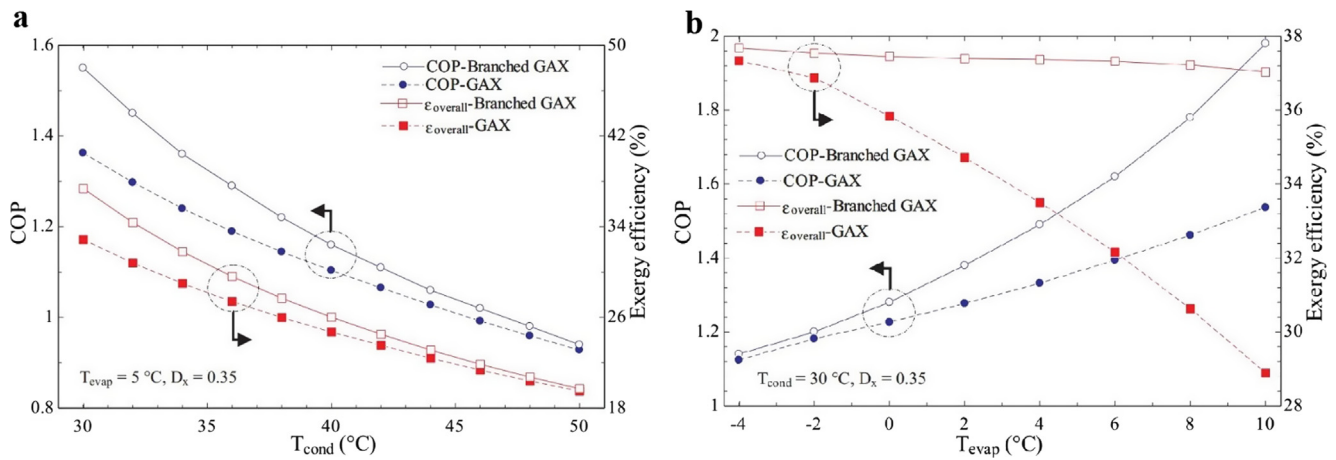

Fig. 30 Effect of (a) condenser temperature and (b) evaporator temperature on COP and exergy efficiency in a branched GAX cycle (Reprinted from Kholghi and Mahmoudi [81], with permission from publisher).

cycle was larger at higher generation temperatures and lower evaporation temperatures, with the maximum COP achieved at the highest coolant temperature.

Xu and Dai [31] investigated a double-effect H_2O -LiBr absorption cooling system in the parallel flow scheme to analyse the effect of various design parameters like the ratio of heat-recovery, solution circulation and ratio of solution distribution on the system efficiency. The results illustrated that the COP improved with an enhancement in the distribution ratio of the solution and/or a decrease in the solution circulation ratio. Moreover, increased heat recovery ratio of the low-temperature and high-temperature heat exchangers led to enhanced system COP. The efficiency of a double-effect cycle with the mixture of ammonia and water was analysed by Adewusi and Zubair [178]. It was observed that the cycle COP was equal to 0.734 when the operating temperatures of 198 °C, -10 °C and 40 °C were selected for the generator, evaporator and absorber/condenser, respectively. The COP experienced a considerable increase and it reached 0.9 when the temperatures of the absorber and condenser dropped to 30 °C. There was also a further rise in the system performance as reaching 1.1 when the evaporation temperature reached 5 °C. Ventas et al. [179] proposed a novel two-stage double-effect absorption system with NH_3 -LiNO₃ solution for combined cold and power generation. It was found that an increment in the generation pressure and a reduction in the absorption temperature improved the energy performance of the system. Moreover, the efficiency of the proposed cycle was 32% larger than that of the double-effect cycle in parallel-flow mode. Recently, Azhar and Siddiqui [180] performed an energetic investigation of a LiBr- H_2O double-effect vapour absorption cycle to optimize the working temperatures in the major generator, the subsidiary generator and the condenser for achieving the highest performance in the system. Kholghi and Mahmoudi [81] performed a parametric study to analyse the influence of some design variables. The condensation temperature and the evaporation temperature on the COP and the exergy efficiency in a branched GAX cycle were examined. The results revealed that the COP and the exergy efficiency heavily depended on the condenser temperature as the system efficiency dropped considerably as the condenser temperature increased reaching 50 °C, Fig. 30a. In addition, increasing

the evaporation temperature exerted an opposite effect on the COP and the exergy efficiency. It is observable from Fig. 30b that the COP increased by 73.68% and the exergy efficiency decreased by 1.46% when the evaporator temperature increased from -4 °C to 10 °C.

Garosi Farshi et al. [154] presented an exergy-economic examination of a double-effect LiBr- H_2O absorption refrigeration system for three different configurations. The authors analysed the cost of system construction under different working conditions. It was observed that the highest and lowest costs were associated with the series and revers flow types, respectively. Xu et al. [32] conducted a theoretical study to analyse a double-effect LiBr- H_2O absorption refrigeration system in the series flow layout. They indicated that the coefficient of performance experienced a minimal decrease as the solution concentration increased. The thermal balance between the low-pressure desorber (LPD) and the high-pressure condenser (HPC) impose significant effects on the efficiency of the absorption system. Indeed, the LPG can use the heat released from the HPC as a source of energy. In this regard, Yilmaz et al. [181] performed a thermodynamic investigation for the HPC of a double-effect H_2O /LiBr absorption refrigeration system in the series flow mode. They reported that the system COP can be improved by the appropriate selection of the HPC temperature.

Karamangil et al. [104] analysed the influence of working factors such as the condensation, generation, absorption, and evaporation temperatures on the COP in a single-stage absorption refrigeration system. The results revealed that the energy efficiency of the system increased by increasing the generation and evaporation temperatures. On the other hand, the COP experienced a decline with increasing the condensation and absorption temperatures. The results agreed with numerical results of Sun [118] and experimental results of Aphornratana and Sriveerakul [182]. Atmaca et al. [183] investigated the influences of inlet working fluid temperatures including the chilled water, hot water, and cooling water passing through the evaporator, generator, and absorber, respectively. They demonstrated that the absorber surface area reduced with increasing of the chilled water and hot water while it enlarged as the cooling water increased. In addition, the COP showed different behaviours toward an increase in the chilled water

and cooling water as it increased with the former but experienced a decline with the latter. Patel et al. [184] performed a comprehensive thermodynamic study of a LiBr-H₂O absorption refrigeration system with a cooling capacity of 140 kW. The influence of exit temperature of the major components on the system performance was analysed in their work. The results displayed that the COP benefited from a higher value for lower temperatures in the exit of the condenser and generator. However, there was a gradual decrease in the system performance as the temperatures increased. This was mainly because of an increment in the circulation ratio and heat load at the absorber and generator as well as a reduction in the concentration of strong solution. Shiue et al. [185] conducted a numerical study to analyse the influence of different operating conditions on the energy performance of a LiBr-H₂O absorption chiller driven by waste heat from municipal solid incineration. The authors found that increasing the heat exchanger effectiveness and the high-pressure generator temperature can lead to an increase in the performance of the system. In addition, the results revealed that the COP can be also increased by decreasing the absorber and condenser temperatures, and/or improving the loading factor of the system. Wonchala et al. [13] executed a parametric investigation of a single-effect absorption cooling system applying LiBr/H₂O working pair. The influence of various key parameters such as the heat source temperature, the main components temperatures and the effectiveness of solution heat exchanger on the system performance was investigated. The results disclosed that the cycle performance was significantly affected by the all studied parameters. Modi et al. [186] numerically modelled a single-effect LiBr/H₂O absorption refrigeration system. Fig. 31 exhibits that the COP raised with the increase of the generator temperature (75 °C to 110 °C) but it remained relatively constant with further increase in the generator temperature. Furthermore, it was found that the COP improved with a decrease in the absorber and condenser temperatures from 45 °C to 30 °C. Horuz and Callander [187] conducted an experimental study of the efficiency of a commercially available vapour absorption refrigeration system of 10 kW cooling capacity. It was found that the system operated with higher performance if the cooling source temperature of the absorber was larger than that of the condenser. It was also observed that the cooling capacity increased when there was an increment in the cooling water flow rate for the condenser. Marcos et al. [188] demonstrated a novel approach to optimize the performance in water- and air-cooled single and double-effect absorption chillers applying LiBr/H₂O solution. They managed to demonstrate properly the influence of various working parameters such as the solution concentration and the condensation temperature on the system efficiency by applying their new method. In this way, one could clearly define the limitations of the crystallization in various conditions; this was especially the case in the design of air-cooled chillers.

Azhar and Siddiqui [189] carried out an exergy analysis of single to triple effect direct and indirect fired absorption systems using H₂O-LiBr working pair. They focused on optimization of the single to triple effect cycles for various operating conditions. Optimum parameters in different components for maximum exergy coefficient of performance and minimum exergy destruction rate were determined. The results indicated that the double-effect cycle had a greater exergy performance when the temperature difference between the heat source and

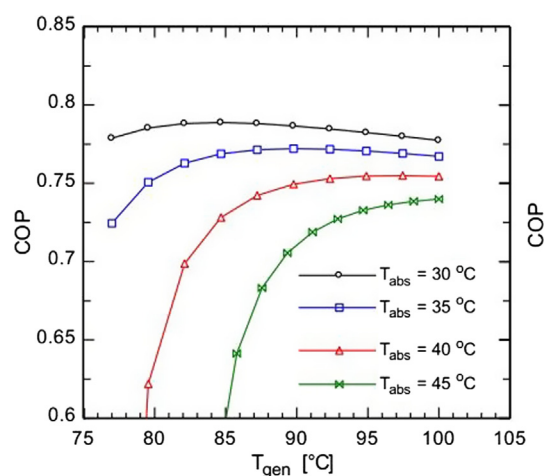

Fig. 31 Effect of generator temperature on COP for four absorber temperatures (Reprinted from Modi et al. [186], with permission from publisher).

the generator varied between 6 and 37 °C. On the other hand, the tripe-effect cycle showed a high exergy performance when the temperature difference was above 37 °C. Gao et al. [127] analysed the effect of different operating parameters on the system performance based on the first and second thermodynamics law. They found that both the COP and exergetic efficiency of the system improved by the application of the air-cooled non-adiabatic absorber. Moreover, the results revealed that the total exergy destruction of the system was significantly affected by the solution heat exchanger and the generator. Iranmanesh and Mehrabian [190] performed a dynamic simulation of a single-effect LiBr-H₂O absorption refrigeration cycle. The influences of thermal masses of main components on both cycle performance and the exergetic efficiency was analysed. They concluded that the high-pressure components were highly affected by thermal masses, while the effect of thermal masses on the low-pressure components were minor. Furthermore, it was disclosed that the thermal mass of the condenser had the most significant effect on the COP and the exergetic efficiency as compared to that of other components. Myat et al. [191] conducted a work to study the performance of a single-effect absorption refrigeration system using an entropy generation analysis. They managed to demonstrate a second law analysis with specific entropy minimization by applying the genetic algorithm tool. The results showed that a decrease in the entropy generation resulted in the maximization of the chiller COP. Ochoa et al. [192] analysed the effect of the variations of the overall heat transfer coefficient as a function of the thermophysical properties on the dynamic efficiency of a single-effect LiBr-H₂O absorption chiller. The authors managed to demonstrate why increasing the hot water temperature cannot lead, necessarily, to an improvement in the COP of the system. In another investigation, Ramesh kumar et al. [162] provided a detailed model of heat transfer of the GAX absorption compression system using solution of H₂O-NH₃. The authors studied the influence of heat transfer conductance, UA, of each component on the performance and cooling capacity of the system. It was observed that the UA of the generator and absorber exerted a considerable effect on the system

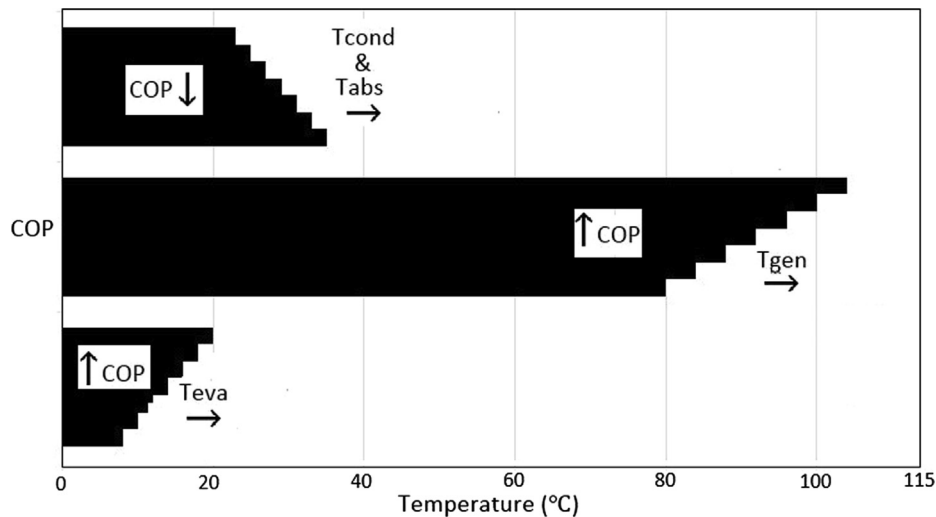

Fig. 32 COP variation with main components temperature for absorption system.

efficiency. The highest performance of the system was obtained for the minimum value of the UA in the all heat exchanger components.

As observed throughout the manuscript, the COP of an absorption cooling system is affected by different operating conditions, especially the temperature of the four main system components. Fig. 32 shows the changes in the COP with the variations of the temperatures of generator, condenser, evaporator and the absorber. According to this figure, the COP increases with the generator and evaporator temperatures. On the other hand, any increase in the condenser and absorber temperatures causes a decrease in the system COP. Compared to the temperature of the other system components, the generator temperature variations have the most significant influence on the COP.

6. Current and future aspects of developments

The present review of various investigations performed on different aspects of the absorption refrigeration technology demonstrated that many attempts have been made to promote such systems in terms of performance and reliability and develop innovative applications of this technology. In spite of the considerable improvements in the system efficiency, further research is required to enhance the absorption systems in the following areas:

- i) improving new working fluid pairs and preventing corrosion to bring down the cost of the system;
- ii) introducing advanced heat recovery strategies to enhance the heat recovery across the system while avoiding design complexities by integrating subcomponents into the system;
- iii) designing new absorption cycles and higher-performance absorbers and generators; and
- iv) extending the utilization of low-grade thermal sources (e.g., solar and geothermal energies) for application of absorption technology.

7. Conclusion

The most significant efforts to develop strategies for enhancing the performance of absorption refrigeration systems were reviewed. These included developments in the cycle design, heat recovery cycles, working fluids, combination of the absorption cycle with particular subcomponents, and optimizing the operating conditions. A summary of the findings is presented in the following:

- Different types of absorption cycles have been designed with different the numbers of effects and stages. According to the literature, the single-effect absorption cycle represents the standard absorption cycle to which the efficiencies of almost all other absorption cycles are compared.
- Double-effect absorption systems have been proposed to improve the system performance when high-temperature thermal sources of energy are available.
- The best energy performance has been achieved by the triple-effect absorption cycle followed by double-effect and single-effect cycles.
- In general, multi-effect absorption systems, and in particular, triple-effect cycles have registered higher performance compared to the single- and double-effect absorption cycles, although an increase in the number of effects cannot necessarily favor the system performance due to the resultant increase in the complexity and average total cost of the system. Moreover, higher-temperature thermal sources are required to drive multi-effect cycles.
- Single-effect double-lift absorption cycle has been proposed when the heat source temperature is very low. This cycle, however, may not produce comparable performance to that of single-effect cycles.
- Heat recovery cycles, and particularly GAX cycles, are simple to understand and contribute to the energy performance of the absorption refrigeration system significantly.
- Branched GAX cycle has been more efficient than GAX cycle, as far as the heat recovery was concerned, as it produces higher performance at lower heat input temperature.

- Other advanced cycles have been also proposed to further improve the system performance. Regeneration absorption cycle, for example, is an advanced heat recovery cycle in which the COP is enhanced by 30% over the simple GAX cycle.
- Although different working fluid pairs, such as ternary and quaternary solutions, have been developed to provide a better energy performance for especial applications, two main working fluid pairs including LiBr-H₂O and H₂O-NH₃ have been the most prominent cases in the absorption cycles for general usage.
- Sub-components (*e.g.*, SHE, flash tank and distillation column) can be added to an absorption cycle to rise its COP and CC and appropriate it for low-grade thermal sources.
- The absorption cycles with integrated ejector or compressor could produce enhanced energy efficiency, as compared to simple cycles.
- Single-effect absorption systems have been extensively studied, with the impacts of different working parameters on the system performance examined.
- The system performance can be enhanced by optimizing the operating conditions (*e.g.*, temperature and flow rate). Generation temperature, for instance, imposes significant contributions to the energy efficiency.

Declaration of Competing Interest

The authors declare that there is no conflict of interest regarding the publication of this article.

References

- [1] A. Sur, R.K. Das, Review on solar adsorption refrigeration cycle, *Int. J. Mech. Eng. Technol. (IJMET)* 1 (2010) 190–226.
- [2] M. Siddiqui, S. Said, A review of solar powered absorption systems, *Renew. Sustain. Energy Rev.* 42 (2015) 93–115.
- [3] W. Wu, B. Wang, W. Shi, X. Li, An overview of ammonia-based absorption chillers and heat pumps, *Renew. Sustain. Energy Rev.* 31 (2014) 681–707.
- [4] H. Yabase, K. Makita, Steam driven triple effect absorption solar cooling system (2012).
- [5] Y. Yuan, X. Cao, L. Sun, B. Lei, N. Yu, Ground source heat pump system: A review of simulation in China, *Renew. Sustain. Energy Rev.* 16 (2012) 6814–6822.
- [6] D. Wang, Y. Li, D. Li, Y. Xia, J. Zhang, A review on adsorption refrigeration technology and adsorption deterioration in physical adsorption systems, *Renew. Sustain. Energy Rev.* 14 (2010) 344–353.
- [7] M. Anisur, M. Mahfuz, M. Kibria, R. Saidur, I. Metselaar, T. Mahlia, Curbing global warming with phase change materials for energy storage, *Renew. Sustain. Energy Rev.* 18 (2013) 23–30.
- [8] H. Hassan, A. Mohamad, A review on solar cold production through absorption technology, *Renew. Sustain. Energy Rev.* 16 (2012) 5331–5348.
- [9] Y. Morabiya, T. Shaikh, Review of solar absorption refrigeration system using LiBr-water and simulate the performance of the system, *IJAERS II* (2013) 57–60.
- [10] H.-M. Henning, Solar assisted air conditioning of buildings—an overview, *Appl. Therm. Eng.* 27 (2007) 1734–1749.
- [11] P.S. Arshi Banu, N.M. Sudharsan, Feasibility studies of single-effect H₂O-LiBr+LiI + LiNO₃+LiCl vapour absorption cooling system for solar based applications, *J Chem Pharm Sci* 12 (2017) 1–7.
- [12] O. Kaynakli, M. Kilic, Theoretical study on the effect of operating conditions on performance of absorption refrigeration system, *Energy Convers. Manage.* 48 (2007) 599–607.
- [13] J. Wonchala, M. Hazledine, K.G. Boulama, Solution procedure and performance evaluation for a water–LiBr absorption refrigeration machine, *Energy* 65 (2014) 272–284.
- [14] M. Medrano, M. Bourouis, A. Coronas, Double-lift absorption refrigeration cycles driven by low-temperature heat sources using organic fluid mixtures as working pairs, *Appl. Energy* 68 (2001) 173–185.
- [15] C. Ying, Z. Yuqun, G. Wei, Z. Jun, SE/DL absorption refrigeration cycle driven by low temperature heat resources, *Acta Energetica Solaris Sinica* 23 (2002) 102–107.
- [16] C.J. Schweigler, P. Riesch, S. Demmel, G. Alefeld, A new absorption chiller to establish combined cold, heat, and power generation utilizing low-temperature heat, American Society of Heating, Refrigerating and Air-Conditioning Engineers, Inc., Atlanta, GA (United States), 1996, 0001-2505.
- [17] A. Yattara, Y. Zhu, M.M. Ali, Comparison between solar single-effect and single-effect double-lift absorption machines (Part I), *Appl. Therm. Eng.* 23 (2003) 1981–1992.
- [18] P. Lin, R. Wang, Z. Xia, Numerical investigation of a two-stage air-cooled absorption refrigeration system for solar cooling: cycle analysis and absorption cooling performances, *Renew. Energy* 36 (2011) 1401–1412.
- [19] S. Du, R. Wang, P. Lin, Z. Xu, Q. Pan, S. Xu, Experimental studies on an air-cooled two-stage NH₃-H₂O solar absorption air-conditioning prototype, *Energy* 45 (2012) 581–587.
- [20] X. Yan, G. Chen, D. Hong, S. Lin, L. Tang, A novel absorption refrigeration cycle for heat sources with large temperature change, *Appl. Therm. Eng.* 52 (2013) 179–186.
- [21] A.A. Sabbagh, J.M. Gómez, Optimal control of single stage LiBr/water absorption chiller, *Int. J. Refrig.* 92 (2018) 1–9.
- [22] R. López-Zavala, N. Velázquez-Limón, L. González-Uribe, J. Aguilar-Jiménez, J. Alvarez-Mancilla, A. Acuña, et al, A novel LiBr/H₂O absorption cooling and desalination system with three pressure levels, *Int. J. Refrig.* 99 (2019) 469–478.
- [23] S. Kaushik, S. Chandra, Computer modeling and parametric study of a double effect generation absorption refrigeration cycle, *Energy Convers. Manage.* 25 (1985) 9–14.
- [24] G.C. Vliet, M.B. Lawson, R.A. Lithgow, Water-lithium bromide double-effect absorption cooling analysis, Univ., Austin (USA). Center for Energy Studies, Texas, 1980.
- [25] R. Gomri, R. Hakimi, Second law analysis of double effect vapour absorption cooler system, *Energy Convers. Manage.* 49 (2008) 3343–3348.
- [26] A. Arora, S. Kaushik, Theoretical analysis of LiBr/H₂O absorption refrigeration systems, *Int. J. Energy Res.* 33 (2009) 1321–1340.
- [27] L. Domínguez-Inzunza, J. Hernández-Magallanes, M. Sandoval-Reyes, W. Rivera, Comparison of the performance of single-effect, half-effect, double-effect in series and inverse and triple-effect absorption cooling systems operating with the NH₃–LiNO₃ mixture, *Appl. Therm. Eng.* 66 (2014) 612–620.
- [28] L. Domínguez-Inzunza, M. Sandoval-Reyes, J. Hernández-Magallanes, W. Rivera, Comparison of the performance of single effect, half effect, double effect in series and inverse absorption cooling systems operating with the mixture H₂O-LiBr, *Energy Procedia* 57 (2014) 2534–2543.
- [29] R. Ventas, A. Lecuona, C. Vereda, M. Legrand, Two-stage double-effect ammonia/lithium nitrate absorption cycle, *Appl. Therm. Eng.* 94 (2016) 228–237.
- [30] A. Lubis, J. Jeong, N. Giannetti, S. Yamaguchi, K. Saito, H. Yabase, et al, Operation performance enhancement of single-

- double-effect absorption chiller, *Appl. Energy* 219 (2018) 299–311.
- [31] G. Xu, Y. Dai, Theoretical analysis and optimization of a double-effect parallel-flow-type absorption chiller, *Appl. Therm. Eng.* 17 (1997) 157–170.
- [32] G. Xu, Y. Dai, K. Tou, C. Tso, Theoretical analysis and optimization of a double-effect series-flow-type absorption chiller, *Appl. Therm. Eng.* 16 (1996) 975–987.
- [33] L.G. Farshi, S.S. Mahmoudi, M. Rosen, Analysis of crystallization risk in double effect absorption refrigeration systems, *Appl. Therm. Eng.* 31 (2011) 1712–1717.
- [34] C. Han, J. Ji, W. He, G. Pei, Theoretical study of dual-heat mode operation of a double-effect parallel-flow LiBr-H₂O absorption refrigeration system, *J. Univ. Sci. Technol. China* 1 (2010) 006.
- [35] Z. Li, J. Liu, Appropriate heat load ratio of generator for different types of air cooled lithium bromide–water double effect absorption chiller, *Energy Convers. Manage.* 99 (2015) 264–273.
- [36] G. Grossman, K. Gommed, D. Gadoth, A computer model for simulation of absorption systems in flexible and modular form, *Faculty Mech. Eng.* (1991).
- [37] M. Yang, S.Y. Lee, J.T. Chung, Y.T. Kang, High efficiency H₂O/LiBr double effect absorption cycles with multi-heat sources for tri-generation application, *Appl. Energy* 187 (2017) 243–254.
- [38] L. Garousi Farshi, S. Seyed Mahmoudi, M. Rosen, M. Yari, A comparative study of the performance characteristics of double-effect absorption refrigeration systems, *Int. J. Energy Res.* 36 (2012) 182–192.
- [39] M. Arun, M. Maiya, S.S. Murthy, Performance comparison of double-effect parallel-flow and series flow water–lithium bromide absorption systems, *Appl. Therm. Eng.* 21 (2001) 1273–1279.
- [40] M. Arun, M. Maiya, S.S. Murthy, Equilibrium low pressure generator temperatures for double-effect series flow absorption refrigeration systems, *Appl. Therm. Eng.* 20 (2000) 227–242.
- [41] M. Chahartaghi, H. Golmohammadi, A.F. Shojaei, Performance analysis and optimization of new double effect lithium bromide–water absorption chiller with series and parallel flows, *Int. J. Refrig.* 97 (2019) 73–87.
- [42] D. Konwar, T. Gogoi, A. Das, Multi-objective optimization of double effect series and parallel flow water–lithium chloride and water–lithium bromide absorption refrigeration systems, *Energy Convers. Manage.* 180 (2019) 425–441.
- [43] R. DeVault, J. Marsala, Ammonia-water triple-effect absorption cycle, Oak Ridge National Lab., TN (USA), 1990.
- [44] J.T.S.P.D. Erickson, Triple effect absorption cycles, in: *Proceedings of the 31st Intersociety Energy Conversion Engineering Conference*, pp. 1072–1077, 1996.
- [45] T. Oouchi, S. Usui, T. Fukuda, A. Nishiguchi, Multi-stage absorption refrigeration system, ed: Google Patents, 1985.
- [46] R.C. DeVault, Triple effect absorption chiller utilizing two refrigeration circuits, ed: Google Patents, 1988.
- [47] R.C. DeVault, W.J. Biermann, Triple-effect absorption refrigeration system with double-condenser coupling, 1993.
- [48] G. Grossman, M. Wilk, R. DeVault, Simulation and performance analysis of triple-effect absorption cycles, Oak Ridge National Lab., TN (United States), 1993.
- [49] Y. Kaita, Simulation results of triple-effect absorption cycles, *Int. J. Refrig.* 25 (2002) 999–1007.
- [50] R. Gomri, Investigation of the potential of application of single effect and multiple effect absorption cooling systems, *Energy Convers. Manage.* 51 (2010) 1629–1636.
- [51] R. Maryami, A. Dehghan, An exergy based comparative study between LiBr/water absorption refrigeration systems from half effect to triple effect, *Appl. Therm. Eng.* 124 (2017) 103–123.
- [52] M.E. Álvarez, X. Esteve, M. Bourouis, Performance analysis of a triple-effect absorption cooling cycle using aqueous (lithium, potassium, sodium) nitrate solution as a working pair, *Appl. Therm. Eng.* 79 (2015) 27–36.
- [53] T. Li, R. Wang, J. Kiplagat, L. Wang, R. Oliveira, A conceptual design and performance analysis of a triple-effect solid–gas thermochemical sorption refrigeration system with internal heat recovery, *Chem. Eng. Sci.* 64 (2009) 3376–3384.
- [54] L. Wang, S. You, H. Zhang, X. Li, Simulation of gas-fired triple-effect LiBr/water absorption cooling system with exhaust heat recovery generator, *Trans. Tianjin Univ.* 16 (2010) 187–193.
- [55] R. Lizarte, J. Marcos, COP optimisation of a triple-effect H₂O/LiBr absorption cycle under off-design conditions, *Appl. Therm. Eng.* 99 (2016) 195–205.
- [56] P. Satzger, Improvement of energy efficiency of cascading sorption machines, in: *International Ab-Sorption Heat Pump Conference (Montreal, Canada)*, 1996, pp. 121–128.
- [57] P. Satzger, F. Ziegler, G. Alefeld, D. Stitou, B. Spinner, Advanced sorption chillers for gas cooling, “American Society of Heating 0001-2505, Refrigerating and Air-Conditioning Engineers, Inc., Atlanta, GA (United States), 1996.
- [58] G. Grossman, R.C. DeVault, F.A. Creswick, Simulation and performance analysis of an ammonia-water absorption heat pump based on the generator-absorber heat exchange (GAX) cycle, Oak Ridge National Lab., TN (United States), 1995.
- [59] T.A.H. Ratlamwala, I. Dincer, M. Gadalla, Thermodynamic analysis of a novel integrated geothermal based power generation-quadruple effect absorption cooling-hydrogen liquefaction system, *Int. J. Hydrogen Energy* 37 (2012) 5840–5849.
- [60] K. Cheung, Y. Hwang, J. Judge, K. Kolos, A. Singh, R. Radermacher, Performance assessment of multistage absorption cycles, *Int. J. Refrig.* 19 (1996) 473–481.
- [61] R.C. DeVault, W.J. Biermann, Seven-effect absorption refrigeration, ed: Google Patents, 1989.
- [62] W.T. Hanna, W.H. Wilkinson, J.H. Saunders, D. Phillips, Pinch-point analysis: an aid to understanding the GAX absorption cycle, American Society of Heating, Refrigerating and Air-Conditioning Engineers., Atlanta, GA (United States), 1995.
- [63] D.K. Priedeman, R.N. Christensen, GAX absorption cycle design process, *ASHRAE Trans.* 105 (1999) 769.
- [64] D. Zheng, W. Deng, H. Jin, J. Ji, α -h diagram and principle of exergy coupling of GAX cycle, *Appl. Therm. Eng.* 27 (2007) 1771–1778.
- [65] D.K. Priedeman, M.A. Garrabrant, J.A. Mathias, R.E. Stout, R.N. Christensen, Performance of a residential-sized GAX absorption chiller, *Trans.-American Soc. Mech. Eng. J. Energy Resour. Technol.* 123 (2001) 236–241.
- [66] G. Anand, “Sub-ambient absorber GAX cycle,” ed, Google Patents (1999).
- [67] N. Velázquez, R. Best, Methodology for the energy analysis of an air cooled GAX absorption heat pump operated by natural gas and solar energy, *Appl. Therm. Eng.* 22 (2002) 1089–1103.
- [68] C.W. Park, J. Koo, Y.T. Kang, Performance analysis of ammonia absorption GAX cycle for combined cooling and hot water supply modes, *Int. J. Refrig.* 31 (2008) 727–733.
- [69] R. Saravanan, G. Rengasamy, S. Arivazhagan, K. Sivakumar, C. Narendran, Renewable based 40 TR ammonia water GAX absorption cooling system, *Proceedings of the international sorption heat pump conference*, 2008.
- [70] Y.T. Kang, H. Hong, K.S. Park, Performance analysis of advanced hybrid GAX cycles: HGAX, *Int. J. Refrig.* 27 (2004) 442–448.
- [71] M. Udayakumar, Studies of compressor pressure ratio effect on GAXAC (generator-absorber-exchange absorption compression) cooler, *Appl. Energy* 85 (2008) 1163–1172.

- [72] A. Mehr, V. Zare, S. Mahmoudi, Standard GAX versus hybrid GAX absorption refrigeration cycle: from the view point of thermoeconomics, *Energy Convers. Manage.* 76 (2013) 68–82.
- [73] M. Dixit, A. Arora, S. Kaushik, Thermodynamic and thermoeconomic analyses of two stage hybrid absorption compression refrigeration system, *Appl. Therm. Eng.* 113 (2017) 120–131.
- [74] S. Du, R. Wang, A unified single stage ammonia-water absorption system configuration with producing best thermal efficiencies for freezing, air-conditioning and space heating applications, *Energy* (2019).
- [75] K. Herold, The branched GAX absorption heat pump cycle, Tokyo: Proceedings of International Absorption Heat Pump Conference, Sep30.-Oct. 2, 1991, 1991.
- [76] K.E. Herold, R. Radermacher, S.A. Klein, Absorption chillers and heat pumps, CRC Press, 2016.
- [77] D.C. Erickson, G. Anand, R.A. Papar, Branched GAX cycle gas fired heat pump, in: Proceedings of the 31st Intersociety Energy Conversion Engineering Conference, 1996. IECEC 96, 1996, pp. 1078–1083.
- [78] M. Staicovici, Polybranched regenerative GAX cooling cycles, *Int. J. Refrig.* 18 (1995) 318–329.
- [79] A. Zaltash, G. Grossman, Simulation and performance analysis of basic GAX and advanced GAX cycles with ammonia/water and ammonia/water/LiBr absorption fluids, Oak Ridge National Lab., TN (United States), 1996.
- [80] M. Engler, G. Grossman, H.-M. Hellmann, Comparative simulation and investigation of ammonia-water: absorption cycles for heat pump applications, *Int. J. Refrig.* 20 (1997) 504–516.
- [81] S.A. Kholghi, S.M.S. Mahmoudi, Energy and exergy analysis of a modified absorption cycle: A comparative study, *Sustain. Energy Technol. Assess.* 32 (2019) 19–28.
- [82] S. Kandlikar, A new absorber heat recovery cycle to improve COP of aqua-ammonia absorption refrigeration system, American Society of Heating, Refrigerating and Air-Conditioning Engineers (ASHRAE), 1982.
- [83] S. Kaushik, R. Kumar, A comparative study of an absorber heat recovery cycle for solar refrigeration using NH₃-refrigerant with liquid/solid absorbents, *Int. J. Energy Res.* 11 (1987) 123–132.
- [84] M.A. Siddiqui, Economic analyses and performance study of three ammonia-absorption cycles using heat recovery absorber, *Energy Convers. Manage.* 37 (1996) 421–432.
- [85] S. Kaushik, R. Kumar, Thermodynamic feasibility of an absorber heat recovery cycle for solar airconditioning, *J. Heat Recov. Syst.* 5 (1985) 117–126.
- [86] K. Dao, Advanced regenerative absorption refrigeration cycles, ed: Google Patents, 1990.
- [87] T. Kashiwagi, Progress of absorption heat pump, next generation absorption heat pump research group, ed: Gas Utility Press, Tokyo, 1995.
- [88] S. Gopalnarayanan, R. Radermacher, Analysis of a low pressure triple effect ammonia-water cycle in multiple operation modes, in: International Ab-Sorption Heat Pump Conference (Montreal, Canada), 1996, pp. 253–260.
- [89] D.C. Erickson, Vapor exchange duplex GAX absorption cycle, ed: Google Patents, 1992.
- [90] D.C. Erickson, J. Tang, Semi-GAX cycles for waste heat powered refrigeration, Inst. of Electrical and Electronics Engineers, Piscataway, NJ (United States), 1996.
- [91] T. Toppi, M. Aprile, M. Guerra, M. Motta, Numerical investigation on semi-GAX NH₃-H₂O absorption cycles, *Int. J. Refrig.* 66 (2016) 169–180.
- [92] Y. Kang, Y. Kunugi, T. Kashiwagi, Advanced absorption systems for low temperature applications, in: Proceedings of the International Sorption Heat Pump Conference, Munich, Germany, 1999, pp. 24–26.
- [93] Y. Kang, A. Akisawa, T. Kashiwagi, An advanced GAX cycle for waste heat recovery: WGAX cycle, *Appl. Therm. Eng.* 19 (1999) 933–947.
- [94] G. Anand, D.C. Erickson, Eight - Ton advanced GAX cycle prototype results, *Am. Soc. Mech. Eng. Adv. Energy Syst. Division AES* 40 (2000) 11–16.
- [95] H. Sabir, R. Chretienneau, Y. ElHag, Analytical study of a novel GAX-R heat driven refrigeration cycle, *Appl. Therm. Eng.* 24 (2004) 2083–2099.
- [96] Z. Xu, R. Wang, Z. Xia, A novel variable effect LiBr-water absorption refrigeration cycle, *Energy* 60 (2013) 457–463.
- [97] Z. Xu, R. Wang, Experimental verification of the variable effect absorption refrigeration cycle, *Energy* 77 (2014) 703–709.
- [98] Y. Shi, Q. Wang, D. Hong, G. Chen, Thermodynamic analysis of a novel GAX absorption refrigeration cycle, *Int. J. Hydrogen Energy* 42 (2017) 4540–4547.
- [99] S. Du, R. Wang, X. Chen, Analysis on maximum internal heat recovery of a mass-coupled two stage ammonia water absorption refrigeration system, *Energy* 133 (2017) 822–831.
- [100] P. Holmberg, T. Berntsson, Alternative working fluids in heat transformers, *Ashrae Trans.* 96 (1990) e9.
- [101] N. Eğrican, The second law analysis of absorption cooling cycles, *Heat Recov. Syst. CHP* 8 (1988) 549–558.
- [102] I. Horuz, A comparison between ammonia-water and water-lithium bromide solutions in vapor absorption refrigeration systems, *Int. Commun. Heat Mass Transf.* 25 (1998) 711–721.
- [103] D. Kim, C.I. Ferreira, Analytic modelling of steady state single-effect absorption cycles, *Int. J. Refrig.* 31 (2008) 1012–1020.
- [104] M. Karamangil, S. Coskun, O. Kaynakli, N. Yamankaradeniz, A simulation study of performance evaluation of single-stage absorption refrigeration system using conventional working fluids and alternatives, *Renew. Sustain. Energy Rev.* 14 (2010) 1969–1978.
- [105] M. Aggarwal, R. Agarwal, Thermodynamic properties of lithium nitrate-ammonia mixtures, *Int. J. Energy Res.* 10 (1986) 59–68.
- [106] C.I. Ferreira, Thermodynamic and physical property data equations for ammonia-lithium nitrate and ammonia-sodium thiocyanate solutions, *Sol. Energy* 32 (1984) 231–236.
- [107] S. Kaushik, R. Kumar, Thermodynamic study of a two-stage vapour absorption refrigeration system using NH₃ refrigerant with liquid/solid absorbents, *Energy Convers. Manage.* 25 (1985) 427–431.
- [108] Y.R. Iyoki, S.T. Uemura, Physical and thermal properties of the H₂O-LiBr-lithium nitrate system, *Int. J. Refrig.* 16 (1993) 191–200.
- [109] D. Cai, J. Jiang, G. He, K. Li, L. Niu, R. Xiao, Experimental evaluation on thermal performance of an air-cooled absorption refrigeration cycle with NH₃-LiNO₃ and NH₃-NaSCN refrigerant solutions, *Energy Convers. Manage.* 120 (2016) 32–43.
- [110] J. Patel, B. Pandya, A. Mudgal, Exergy based analysis of LiCl-H₂O absorption cooling system, *Energy Procedia* 109 (2017) 261–269.
- [111] L. Zhu, J. Gu, Thermodynamic analysis of a novel thermal driven refrigeration system, *World Acad. Sci., Eng. Technol.* 56 (2009) 351–355.
- [112] X. She, Y. Yin, M. Xu, X. Zhang, A novel low-grade heat-driven absorption refrigeration system with LiCl-H₂O and LiBr-H₂O working pairs, *Int. J. Refrig.* 58 (2015) 219–234.
- [113] S. Won, W. Lee, Thermodynamic design data for double effect absorption heat pump systems using water-lithium chloride—cooling, *Heat Recov. Syst. CHP* 11 (1991) 41–48.
- [114] S. Won, H. Chung, H. Lee, Simulation and thermodynamic design data study on double-effect absorption cooling cycle using water-LiBr-LiSCN mixture, *Heat Recov. Syst. CHP* 11 (1991) 161–168.

- [115] H.-R. Lee, K.-K. Koo, S. Jeong, J.-S. Kim, H. Lee, Y.-S. Oh, et al, Thermodynamic design data and performance evaluation of the water+ lithium bromide+ lithium iodide+ lithium nitrate+ lithium chloride system for absorption chiller, *Appl. Therm. Eng.* 20 (2000) 707–720.
- [116] D. Cai, G. He, Q. Tian, Y. Bian, R. Xiao, A. Zhang, First law analysis of a novel double effect air-cooled non-adiabatic ammonia/salt absorption refrigeration cycle, *Energy Convers. Manage.* 98 (2015) 1–14.
- [117] S. Iyoki, T. Uemura, Performance characteristics of the water-lithium bromide-zinc chloride-calcium bromide absorption refrigerating machine, absorption heat pump and absorption heat transformer, *Int. J. Refrig.* 13 (1990) 191–196.
- [118] D.-W. Sun, Comparison of the performances of NH₃-H₂O, NH₃-LiNO₃ and NH₃-NaSCN absorption refrigeration systems, *Energy Convers. Manage.* 39 (1998) 357–368.
- [119] M. Bourouis, M. Vallès, M. Medrano, A. Coronas, Performance of air-cooled absorption air-conditioning systems working with water-(LiBr + Lil + LiNO₃ + LiCl), *Proc. Inst. Mech. Eng., Part E: J. Process Mech. Eng.* 219 (2) (2005) 205–213, <https://doi.org/10.1243/095440805X8601>.
- [120] S. Steiu, D. Salavera, J.C. Bruno, A. Coronas, A basis for the development of new ammonia–water–sodium hydroxide absorption chillers, *Int. J. Refrig.* 32 (2009) 577–587.
- [121] A. Coronas, M. Vallès, S.K. Chaudhari, K.R. Patil, Absorption heat pump with the TFE-TEGDME and TFE-H₂O-TEGDME systems, *Appl. Therm. Eng.* 16 (1996) 335–345.
- [122] Z. Zhao, X. Zhang, X. Ma, Thermodynamic performance of a double-effect absorption heat-transformer using TFE/E181 as the working fluid, *Appl. Energy* 82 (2005) 107–116.
- [123] S. Arivazhagan, S. Murugesan, R. Saravanan, S. Renganarayanan, Simulation studies on R134a—DMAC based half effect absorption cold storage systems, *Energy Convers. Manage.* 46 (2005) 1703–1713.
- [124] A. Karno, S. Ajib, Thermodynamic analysis of an absorption refrigeration machine with new working fluid for solar applications, *Heat Mass Transf.* 45 (2008) 71–81.
- [125] G. Moreno-Quintanar, W. Rivera, R. Best, Comparison of the experimental evaluation of a solar intermittent refrigeration system for ice production operating with the mixtures NH₃/LiNO₃ and NH₃/LiNO₃/H₂O, *Renew. Energy* 38 (2012) 62–68.
- [126] M. Donate, L. Rodríguez, A. De Lucas, J.F. Rodríguez, Thermodynamic evaluation of new absorbent mixtures of lithium bromide and organic salts for absorption refrigeration machines, *Int. J. Refrig.* 29 (2006) 30–35.
- [127] Y. Gao, G. He, P. Chen, X. Zhao, D. Cai, Energy and exergy analysis of an air-cooled waste heat-driven absorption refrigeration cycle using R290/oil as working fluid, *Energy* 173 (2019) 820–832.
- [128] M. Olbricht, F. Lonardi, A. Luke, Performance improvement of absorption chillers by means of additives—A numerical study, *Sol. Energy* 166 (2018) 138–145.
- [129] L. Yang, K. Du, S. Bao, Y. Wu, Investigations of selection of nanofluid applied to the ammonia absorption refrigeration system, *Int. J. Refrig.* 35 (2012) 2248–2260.
- [130] L. Yang, K. Du, Y.H. Ding, B. Cheng, Y.J. Li, Viscosity-prediction models of ammonia water nanofluids based on various dispersion types, *Powder Technol.* 215 (2012) 210–218.
- [131] A. Sözen, E. Özbaş, T. Menlik, M.T. Çakır, M. Gürü, K. Boran, Improving the thermal performance of diffusion absorption refrigeration system with alumina nanofluids: An experimental study, *Int. J. Refrig.* 44 (2014) 73–80.
- [132] W. Jiang, S. Li, L. Yang, K. Du, Experimental investigation on performance of ammonia absorption refrigeration system with TiO₂ nanofluid, *Int. J. Refrig.* 98 (2019) 80–88.
- [133] S. Aphornratana, Theoretical and experimental investigation of a combined ejector-absorption refrigerator, University of Sheffield, Department of Mechanical and Process Engineering, 1995.
- [134] A. Sözen, Effect of heat exchangers on performance of absorption refrigeration systems, *Energy Convers. Manage.* 42 (2001) 1699–1716.
- [135] W.J. Koehler, W.E. Ibele, J. Soltes, E.R. Winter, Availability simulation of a lithium bromide absorption heat pump, *Heat Recov. Syst. CHP* 8 (1988) 157–171.
- [136] H. Cho, C. Baek, C. Park, Y. Kim, Performance evaluation of a two-stage CO₂ cycle with gas injection in the cooling mode operation, *Int. J. Refrig.* 32 (2009) 40–46.
- [137] J. Heo, M.W. Jeong, Y. Kim, Effects of flash tank vapor injection on the heating performance of an inverter-driven heat pump for cold regions, *Int. J. Refrig.* 33 (2010) 848–855.
- [138] R. Sirwan, M. Alghoul, K. Sopian, Y. Ali, J. Abdulateef, Evaluation of adding flash tank to solar combined ejector-absorption refrigeration system, *Sol. Energy* 91 (2013) 283–296.
- [139] A.M. Abed, M. Alghoul, K. Sopian, Performance evaluation of flash tank-absorption cooling cycle using two ejectors, *Appl. Therm. Eng.* 101 (2016) 47–60.
- [140] R. Sirwan, M. Alghoul, K. Sopian, Y. Ali, Thermodynamic analysis of an ejector-flash tank-absorption cooling system, *Appl. Therm. Eng.* 58 (2013) 85–97.
- [141] G. Anand, D.C. Erickson, Compact sieve-tray distillation column for ammonia-water absorption heat pump: Part I—design methodology, *ASHRAE Trans.* 105 (1999) 796.
- [142] J. Fernández-Seara, J. Sieres, The importance of the ammonia purification process in ammonia–water absorption systems, *Energy Convers. Manage.* 47 (2006) 1975–1987.
- [143] J. Sieres, J. Fernández-Seara, Experimental investigation of mass transfer performance with some random packings for ammonia rectification in ammonia–water absorption refrigeration systems, *Int. J. Therm. Sci.* 46 (2007) 699–706.
- [144] N. Darwish, S. Al-Hashimi, A. Al-Mansoori, Performance analysis and evaluation of a commercial absorption–refrigeration water–ammonia (ARWA) system, *Int. J. Refrig.* 31 (2008) 1214–1223.
- [145] E. Zavaleta-Aguilar, J. Simões-Moreira, Thermal design of a tray-type distillation column of an ammonia/water absorption refrigeration cycle, *Appl. Therm. Eng.* 41 (2012) 52–60.
- [146] L.-T. Chen, A new ejector-absorber cycle to improve the COP of an absorption refrigeration system, *Appl. Energy* 30 (1988) 37–51.
- [147] A. Sözen, M. Özalp, Performance improvement of absorption refrigeration system using triple-pressure-level, *Appl. Therm. Eng.* 23 (2003) 1577–1593.
- [148] M. Jelinek, A. Levy, I. Borde, Performance of a triple-pressure level absorption cycle, The Second International Heat Powered Cycles Conference, Paris, France, 2001.
- [149] A. Levy, M. Jelinek, I. Borde, Numerical study on the design parameters of a jet ejector for absorption systems, *Appl. Energy* 72 (2002) 467–478.
- [150] C. Vereda, R. Ventas, A. Lecuona, M. Venegas, Study of an ejector-absorption refrigeration cycle with an adaptable ejector nozzle for different working conditions, *Appl. Energy* 97 (2012) 305–312.
- [151] L.G. Farshi, A. Mosaffa, C.I. Ferreira, M. Rosen, Thermodynamic analysis and comparison of combined ejector-absorption and single effect absorption refrigeration systems, *Appl. Energy* 133 (2014) 335–346.
- [152] D.-W. Sun, I.W. Eames, S. Aphornratana, Evaluation of a novel combined ejector-absorption refrigeration cycle—I: computer simulation, *Int. J. Refrig.* 19 (1996) 172–180.
- [153] S. Aphornratana, I.W. Eames, Experimental investigation of a combined ejector-absorption refrigerator, *Int. J. Energy Res.* 22 (1998) 195–207.
- [154] L.G. Farshi, S.S. Mahmoudi, M. Rosen, M. Yari, M. Amidpour, Exergoeconomic analysis of double effect

- absorption refrigeration systems, *Energy Convers. Manage.* 65 (2013) 13–25.
- [155] A. Levy, M. Jelinek, I. Borde, F. Ziegler, Performance of an advanced absorption cycle with R125 and different absorbents, *Energy* 29 (2004) 2501–2515.
- [156] L.G. Farshi, S.S. Mahmoudi, M. Rosen, Exergoeconomic comparison of double effect and combined ejector-double effect absorption refrigeration systems, *Appl. Energy* 103 (2013) 700–711.
- [157] E. Bellos, C. Tzivanidis, Parametric analysis and optimization of a cooling system with ejector-absorption chiller powered by solar parabolic trough collectors, *Energy Convers. Manage.* 168 (2018) 329–342.
- [158] D. Colorado, W. Rivera, Performance comparison between a conventional vapor compression and compression-absorption single-stage and double-stage systems used for refrigeration, *Appl. Therm. Eng.* 87 (2015) 273–285.
- [159] R. Ventas, A. Lecuona, A. Zacarias, M. Venegas, Ammonia-lithium nitrate absorption chiller with an integrated low-pressure compression booster cycle for low driving temperatures, *Appl. Therm. Eng.* 30 (2010) 1351–1359.
- [160] L. Kairouani, E. Nehdi, Cooling performance and energy saving of a compression-absorption refrigeration system assisted by geothermal energy, *Appl. Therm. Eng.* 26 (2006) 288–294.
- [161] J.-S. Kim, F. Ziegler, H. Lee, Simulation of the compressor-assisted triple-effect H₂O/LiBr absorption cooling cycles, *Appl. Therm. Eng.* 22 (2002) 295–308.
- [162] A. Rameshkumar, M. Udayakumar, R. Saravanan, Heat transfer studies on a GAXAC (generator-absorber-exchange absorption compression) cooler, *Appl. Energy* 86 (2009) 2056–2064.
- [163] C. Cimsit, I.T. Ozturk, Analysis of compression-absorption cascade refrigeration cycles, *Appl. Therm. Eng.* 40 (2012) 311–317.
- [164] V. Jain, G. Sachdeva, S. Kachhwaha, Thermodynamic modelling and parametric study of a low temperature vapour compression-absorption system based on modified Gouy-Stodola equation, *Energy* 79 (2015) 407–418.
- [165] J. Wang, B. Wang, W. Wu, X. Li, W. Shi, Performance analysis of an absorption-compression hybrid refrigeration system recovering condensation heat for generation, *Appl. Therm. Eng.* 108 (2016) 54–65.
- [166] Y. Chen, W. Han, H. Jin, Thermodynamic performance optimization of the absorption-generation process in an absorption refrigeration cycle, *Energy Convers. Manage.* 126 (2016) 290–301.
- [167] Y. Chen, W. Han, H. Jin, Analysis of an absorption/absorption-compression refrigeration system for heat sources with large temperature change, *Energy Convers. Manage.* 113 (2016) 153–164.
- [168] Y. Chen, W. Han, H. Jin, Proposal and analysis of a novel heat-driven absorption-compression refrigeration system at low temperatures, *Appl. Energy* 185 (2017) 2106–2116.
- [169] Y. Xu, F. Chen, Q. Wang, X. Han, D. Li, G. Chen, A novel low-temperature absorption-compression cascade refrigeration system, *Appl. Therm. Eng.* 75 (2015) 504–512.
- [170] A. Razmi, M. Soltani, F.M. Kashkooli, L.G. Farshi, Energy and exergy analysis of an environmentally-friendly hybrid absorption/recompression refrigeration system, *Energy Convers. Manage.* 164 (2018) 59–69.
- [171] M. Eisa, P. Diggory, F. Holland, Experimental studies to determine the effect of differences in absorber and condenser temperatures on the performance of a water-lithium bromide absorption cooler, *Energy Convers. Manage.* 27 (1987) 253–259.
- [172] M. Eisa, F. Holland, A study of the operating parameters in a water-lithium bromide absorption cooler, *Int. J. Energy Res.* 10 (1986) 137–144.
- [173] D.-W. Sun, Thermodynamic design data and optimum design maps for absorption refrigeration systems, *Appl. Therm. Eng.* 17 (1997) 211–221.
- [174] H. Chua, H. Toh, A. Malek, K. Ng, K. Srinivasan, Improved thermodynamic property fields of LiBr–H₂O solution, *Int. J. Refrig.* 23 (2000) 412–429.
- [175] M. Mostafavi, B. Agnew, The impact of ambient temperature on lithium-bromide/water absorption machine performance, *Appl. Therm. Eng.* 16 (1996) 515–522.
- [176] A. Şencan, K.A. Yakut, S.A. Kalogirou, Exergy analysis of lithium bromide/water absorption systems, *Renew. Energy* 30 (2005) 645–657.
- [177] S. Du, R. Wang, Z. Xia, Optimal ammonia water absorption refrigeration cycle with maximum internal heat recovery derived from pinch technology, *Energy* 68 (2014) 862–869.
- [178] S. Adewusi, S.M. Zubair, Second law based thermodynamic analysis of ammonia–water absorption systems, *Energy Convers. Manage.* 45 (2004) 2355–2369.
- [179] R. Ventas, A. Lecuona, C. Vereda, M. Rodriguez-Hidalgo, Performance analysis of an absorption double-effect cycle for power and cold generation using ammonia/lithium nitrate, *Appl. Therm. Eng.* 115 (2017) 256–266.
- [180] M. Azhar, M.A. Siddiqui, Energy and exergy analyses for optimization of the operating temperatures in double effect absorption cycle, *Energy Procedia* 109 (2017) 211–218.
- [181] İ.H. Yılmaz, K. Saka, O. Kaynakli, A thermodynamic evaluation on high pressure condenser of double effect absorption refrigeration system, *Energy* 113 (2016) 1031–1041.
- [182] S. Aphornratana, T. Sriveerakul, Experimental studies of a single-effect absorption refrigerator using aqueous lithium-bromide: effect of operating condition to system performance, *Exp. Therm. Fluid Sci.* 32 (2007) 658–669.
- [183] I. Atmaca, A. Yigit, M. Kilic, The effect of input temperatures on the absorber parameters, *Int. Commun. Heat Mass Transf.* 29 (2002) 1177–1186.
- [184] H.A. Patel, L. Patel, D. Jani, A. Christian, Energetic analysis of single stage lithium bromide water absorption refrigeration system, *Procedia Technol.* 23 (2016) 488–495.
- [185] A. Shiu, S.-C. Hu, K.-H. Chiang, Effect of operating variables on performance of an absorption chiller driven by heat from municipal solid waste incineration, *Sustain. Energy Technol. Assess.* 27 (2018) 134–140.
- [186] B. Modi, A. Mudgal, B. Patel, Energy and exergy investigation of small capacity single effect lithium bromide absorption refrigeration system, *Energy Procedia* 109 (2017) 203–210.
- [187] I. Horuz, T. Callander, Experimental investigation of a vapor absorption refrigeration system, *Int. J. Refrig.* 27 (2004) 10–16.
- [188] J. Marcos, M. Izquierdo, E. Palacios, New method for COP optimization in water-and air-cooled single and double effect LiBr–water absorption machines, *Int. J. Refrig.* 34 (2011) 1348–1359.
- [189] M. Azhar, M.A. Siddiqui, Exergy analysis of single to triple effect lithium bromide-water vapour absorption cycles and optimization of the operating parameters, *Energy Convers. Manage.* 180 (2019) 1225–1246.
- [190] A. Iranmanesh, M. Mehrabian, Dynamic simulation of a single-effect LiBr–H₂O absorption refrigeration cycle considering the effects of thermal masses, *Energy Build.* 60 (2013) 47–59.
- [191] A. Myat, K. Thu, Y.-D. Kim, A. Chakraborty, W.G. Chun, K. C. Ng, A second law analysis and entropy generation minimization of an absorption chiller, *Appl. Therm. Eng.* 31 (2011) 2405–2413.
- [192] A. Ochoa, J. Dutra, J. Henríquez, C. Dos Santos, J. Rohatgi, The influence of the overall heat transfer coefficients in the dynamic behavior of a single effect absorption chiller using the pair LiBr/H₂O, *Energy Convers. Manage.* 136 (2017) 270–282.